

Journal of the  
**National**  
**Academy** OF  
**Forensic**  
**Engineers**<sup>®</sup>



<http://www.nafe.org>

ISSN: 2379-3252

Vol. 38 No. 1 June 2021

# Forensic Engineering Analysis of Video Screens for a Dispute Over Requirements and Specifications

By Robert O. Peruzzi, PhD, PE, DFE (NAFE 954M)

## Abstract

*This case was about LCD video screens intended to become components of medical equipment requiring an ultra-wide viewing angle. The seller was a wholesaler of various types of video screens from multiple manufacturers. The buyer was a distributor of multiple electrical components for various industries. The OEM, not involved in the case, was a manufacturer of medical instruments and equipment. Claiming that multiple units did not meet the requirements specified in the purchase agreement, the OEM refused a shipment of 1,000 LCD video screens. The buyer had already paid the seller, who refused to take back the shipment and issue a refund or credit. As a result, the buyer sued seller, and the author investigated and submitted expert opinions regarding the following questions: Did performance differ between examined samples? Did each sample meet data sheet specification for viewing angle? And was each sample adequate for its intended application as advertised in the datasheet (that is, for industrial settings requiring ultra-wide viewing angle)?*

## Keywords

Forensic engineering, thin film transistor liquid crystal diode, TFT-LCD, video screens, medical electronic equipment, product requirements, product specifications, video quality, video viewing angle, subjective analysis

## Background

Component purchase decisions are based on the recommended applications, features, and specifications published in datasheets. This paper concentrates on one specification: viewing angle. For example, a narrow viewing angle may be desirable in laptop video screens to provide privacy to the user. On the other hand, a wide viewing is desirable for wall-mounted televisions, public information kiosks, and industrial information displays, in addition to the medical equipment product in question.

The wide viewing angle was an essential requirement for the video screens of the medical instruments and equipment manufactured and sold by the OEM. End-users of the equipment screens were typically medical professionals needing to see screen contents clearly from either side (above or below).

## Thin Film Transistor (TFT) Color LCD Technology

According to a 2007 article, LCD video screen image quality at publication time was already superior to cathode-ray-tube (CRT) video screens<sup>1</sup>. LCD

applications include PC monitors, cellular phone screens, and televisions. Their advantages (including slim size and lightweight design) made them good replacements for CRTs<sup>2</sup>.

**Figure 1** is a photo of a typical TFT LCD video screen on the author's laptop computer. **Figure 2** is a side view photo of that same computer, showing that it has a wide viewing angle. The following paragraphs and figures describe the operation and technology of TFT LCD video screens.

**Figure 3** is a closeup of 16 complete pixels of a video screen. Each pixel comprises a blue, red, and green rectangular sub-pixel. Each sub-pixel is controlled by a TFT, which is controlled by data signals.

**Figure 4** is a diagram showing the physical layout of a TFT LCD video screen. The diagram indicates:

1. Glass plates

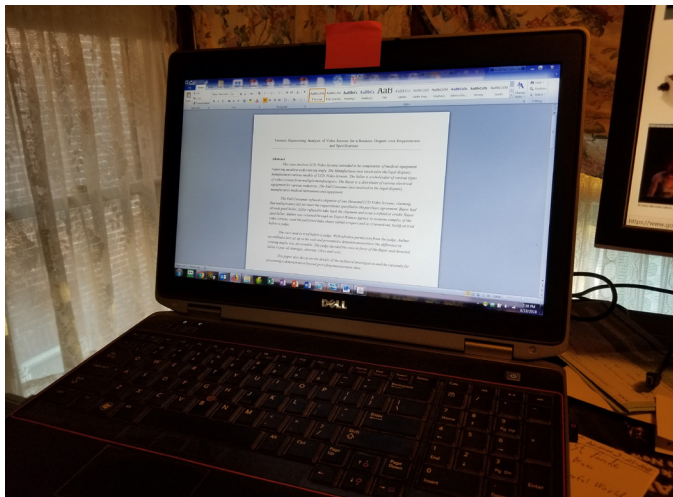

**Figure 1**  
Typical LCD television screen.

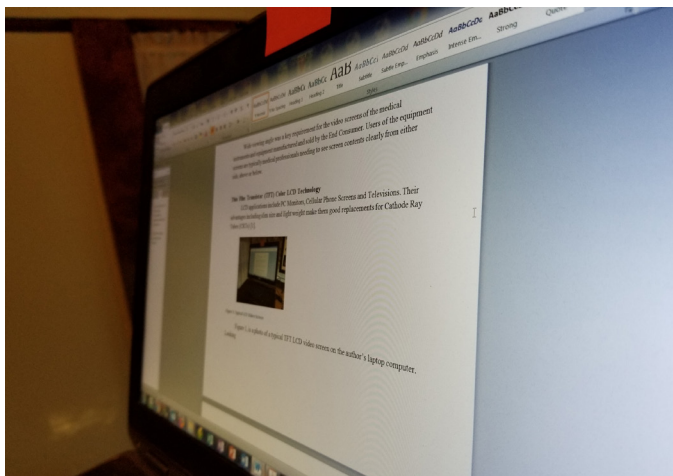

**Figure 2**  
LCD video screen side view.

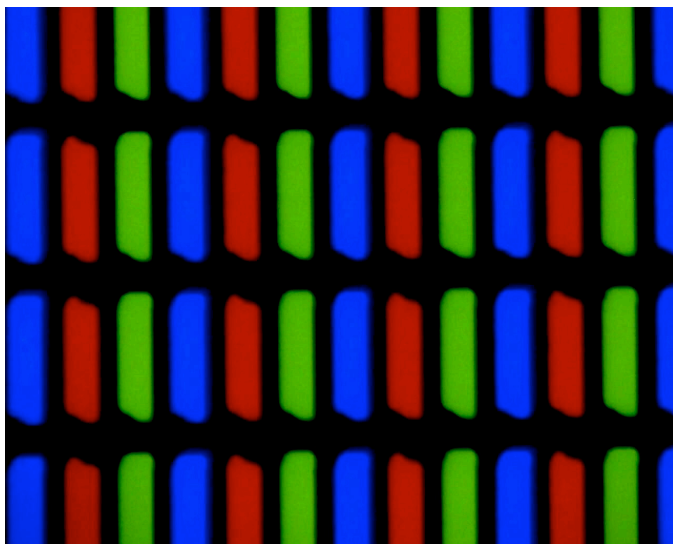

**Figure 3**  
300X close-up of video screen<sup>3</sup>.

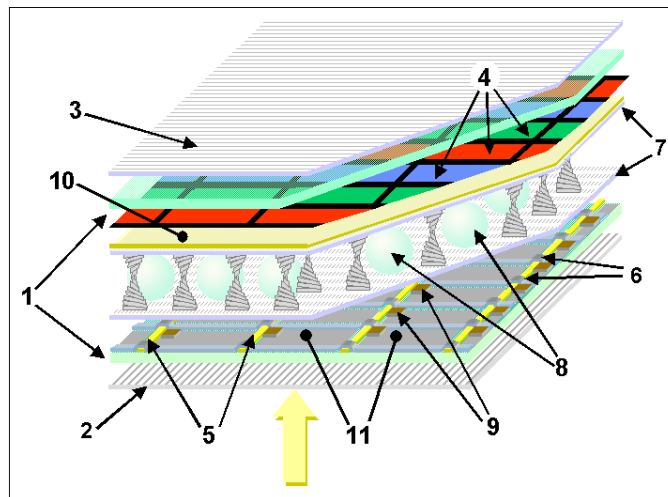
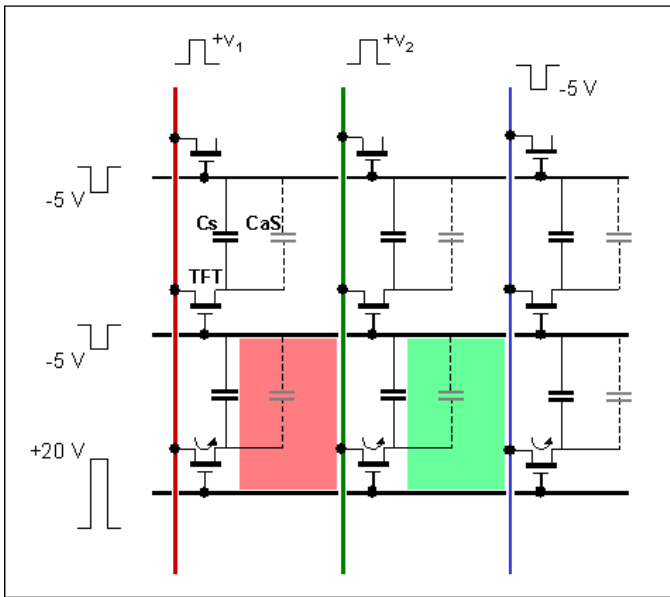

**Figure 4**  
Color TFT LCD layout<sup>4</sup>.

- 2. Vertical polarizer
- 3. Horizontal polarizer
- 4. Red, green, blue (RGB) color mask
- 5. Vertical command lines
- 6. Horizontal command lines
- 7. Rubbed polymer layer
- 8. Spacers
- 9. Thin-film transistors (TFTs)
- 10. Front electrode
- 11. Rear electrodes

The yellow upward-pointing arrow symbolizes light from a white backlight illuminating the video screen. First, the light passes through the vertical polarizer (2), then a lower glass plate (1). TFTs (9) control the capacitive charge deposited on the rear electrodes (11). The voltages on the rear electrodes are controlled by the voltages present on the vertical command lines (5) and the horizontal command lines (6).

**Figure 5** is a partial schematic showing the electrical equivalent of two TFT pixels of an LCD display where the lower pixel is lit yellow. A yellow pixel is generated by energizing the red and green sub-pixels of the bottom pixel.



**Figure 5**  
Color TFT-LCD cells-schematic<sup>5</sup>.

The +20V pulse on the bottom horizontal command line turns on the bottom pixel for a time interval of the pulse duration. The -5V on the middle horizontal command-line turns off the upper pixel during that interval. A top horizontal command line turns off the next higher pixel (not shown). The +V1 vertical command line controls the brightness of the “red” sub-pixel, and +V2 vertical command line controls the brightness of the “green” sub-pixel. The -5V on the rightmost vertical command line turns off the “blue” sub-pixel during that interval.

Referring again to **Figure 4**, light passes through the rear electrodes and into the liquid crystal assembly. The thinness of the electrode dimensions makes them substantially transparent. Liquid crystal is held between the bottom and top “rubbed polymer” layers (7) and spacers (8). This substance is not numbered in the diagram but is symbolized by hourglass-shaped structures between the spacers. The property of interest of liquid crystal is that its opacity is controlled by an electric field due to the voltage present on the rear electrodes<sup>6</sup>. The electric field tends to polarize the orientation of amorphous silicon (A-Si) particles to block or transmit the white light. At this point, the blocked or partially transmitted light beams are shades of “grey.” This modulated grey light passes through the upper rubbed polymer layer (7), and the substantially transparent front electrode (10) to the RGB color mask (4).

The light from each red, green, and blue sub-pixel passes through an upper glass plate (1) and finally the

horizontal polarizer (3). The final step occurs when human perception integrates and blends the light from each sub-pixel into an image.

### Video Screen General Specifications

General specifications for video screens include physical qualities, such as weight, display area monitor dimensions, drive system, number of colors, numbers and dimensions of pixels, contrast ratio, polarizer details, response time, luminance, and power consumption<sup>7</sup>. Readers desiring a deeper understanding of video screens and how their specifications relate to sensory quality may visit EIZO’s website<sup>8</sup>.

### Viewing Angle

Subjectively, the viewing angle specification refers to the maximum angles from the sides and from the top and bottom. The screen is readable, and the colors remain consistent.

A definition and defined measurement technique for determining viewing angle might be expected to help overcome the subjectivity of judging readability and color consistency. In fact, such a standard exists. However, the Information Display Measurements Standard leaves it up to video display manufacturers to choose the measurable “optical quantity” to measure at various angles and define the allowable change in that quantity that defines the maximal viewing angle. Possible optical quantity metrics include contrast ratio, white luminance, black luminance, chromaticity coordinates, and color difference<sup>9</sup>. Ambiguity results in differing measurement techniques.

In 2021, Barczyk et al published their technique using contrast ratio (CR) as their defining optical quantity. They point out that the defined allowable change from CR measured at 0 degrees differs from the manufacturer and may be 5:1, 10:1, or 100:1. In addition, the manufacturer may expand the claimed viewing angle by up to 20 degrees<sup>10</sup>.

Eunjung Lee et al, in 2010, argued that CR should no longer be used as the criterion for determining maximal viewing angle<sup>11</sup>. They claimed 10:1 CR is not adequate and proposed using a combination of brightness, colorfulness, and hue factors as defined in CIECAM02<sup>12</sup>.

Not surprisingly, some manufacturers have used this ambiguity to puff their products<sup>13</sup>. Whatever optical quantity and degradation ratio is chosen as the measurement criterion, a 140-degree viewing angle is illustrated in **Figure 6**.

A wide viewing angle is not always desirable, and viewing angle may be deliberately designed to be narrow for screens where privacy is an issue. Typically, the LCD components are designed for wide viewing angles, and the viewing angle is precisely controlled by the dimensions of the polarizing lines in polarizers **Figure 4**.

In 2007, the manufacturer introduced LCD screens that could be set for narrow or wide viewing angle, and by 2008 it began introducing screens with switchable viewing angle<sup>14</sup>. The transaction for the screens in question was made in 2012.

### The LCD Video Screen Module in Question

The manufacturer supplies the TFT Color LCD Module. Its datasheet<sup>15</sup> claims it to be applicable for industrial use and has ultra-wide viewing angles, high luminance, and high contrast. The viewing angle specification is a minimum of 70 degrees from up, down, left, and right.

The OEM ordered 1,000 units of this make and model video screen from the buyer (plaintiff). The buyer purchased these units from the seller (defendant), a licensed distributor for the manufacturer. Coincidentally, this company also manufactures another TFT Color LCD Module. Its datasheet<sup>16</sup> claims applicable for control system display terminals and industrial PCs and has high luminance and high contrast. The viewing angle specification is a minimum of 35 degrees from the right and left, 20 degrees from up, and 10 degrees from down. Its luminance and contrast specifications are slightly inferior to the other unit, while its other parameter specifications are nearly identical. Both

were excellent video screens at the time. The “-54” version was designed for a limited viewing angle. This change, as expected, degraded its luminance and contrasted optical qualities.

### Prior to the Investigation

An independent testing laboratory specializing in video screens was contracted by the seller to perform a list of tests, which did not include a viewing-angle test. Their test report included:

- Listed all test equipment.
- Documented calibration of test equipment.
- Described the test procedures.
- Reported the measured results.
- Interpreted the measured results, arriving at conclusions.
- Suggested corrective action.

### The Author’s Investigation

The author examined four samples of LCD screens after reviewing the datasheet, and submitted an expert report opining on these questions:

- Does each sample have substantially the same or different performance?
- Does each sample meet data sheet specification for viewing angle?
- Is each sample adequate for the intended application as advertised in the datasheet (that is, for industrial settings requiring ultra-wide viewing angle)?

The buyer delivered four samples for analysis. All were clearly marked TFT Color LCD Module in shipping packaging and on the modules themselves. Exhibit A was marked known-good, Exhibit B was marked “engineering sample,” and Exhibits C and D were unopened as delivered from the seller to the buyer. The LCD screens were bare modules, not mounted in protective frames or including electro-static discharge (ESD) protection. All were packed in ESD-protective bags for shipment. To demonstrate and test the modules, a compatible screen tester<sup>17</sup> with power supply, backlight, and a wiring harness<sup>18</sup> were purchased.

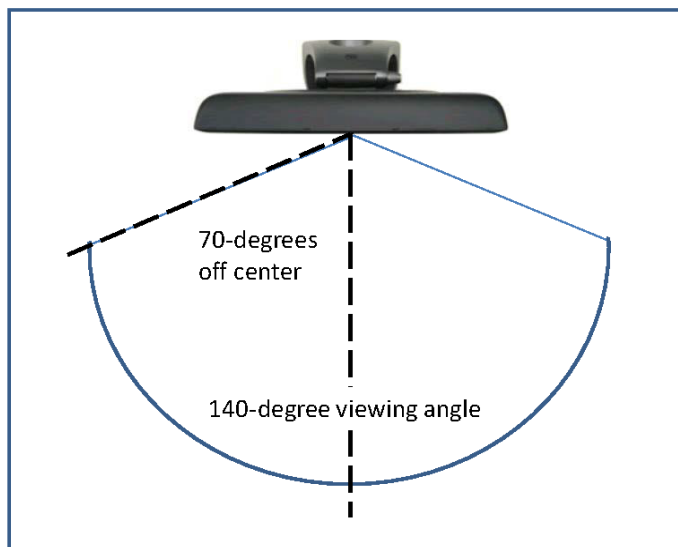

**Figure 6**  
Viewing angle diagram.

**Investigation and Report**

**Test Equipment:**

- |  |                                  |
|--|----------------------------------|
| 1. Dell Vostro Laptop Computer (PC)      | Video source (PC)                |
| 2. VGA Cable (monitor cable)             | PC to LCD driver module          |
| 3. MS453LC-KITMS179DI TTL-DF9-31_640X480 | LCD driver module                |
| 4. 2 Lamp Inverter (Backlight power)     | Special power supply for LCD     |
| 5. 40W(MS112ADP) (Power supply)          | Power supply for everything else |
| 6. Viewpoint control fixture             | Tool for measuring viewing angle |
| 7. ESD wrist strap and kit               | For equipment protection         |

**Test Fixture Connections and Procedure:**

An ESD safety mat covered the surface of the lab bench. An ESD protective wrist strap was worn when setting up the test fixture and throughout the test procedures. Power and signal connections between modules were made with all switches in the off position before plugging power supplies into the power mains.

Exhibit	Package Marking	Observations	Measurements
A	Known Good Panel	<ul style="list-style-type: none"> <li>Chosen as comparison <u>standard</u></li> <li>"Normal" appearance</li> <li>No perceptible color shift as viewpoint approached 90 degrees</li> </ul>	80 degrees in all directions measured at several points
B	Golden Sample for Engineering Evaluation	<ul style="list-style-type: none"> <li>"Normal" appearance</li> <li>No perceptible color shift as viewpoint approached 90 degrees</li> </ul>	80 degrees in all directions measured at several points
C	Panel Received from Seller	<ul style="list-style-type: none"> <li>"Normal appearance when viewed within viewing <u>angle</u></li> <li>Reduced viewing angle observable to naked <u>eye</u></li> <li>Obvious differences from exhibits A and B</li> <li>As viewing angle increased,                             <ul style="list-style-type: none"> <li>Colors changed and quality <u>degraded</u></li> <li>Graphical image sharpness <u>degraded</u></li> <li>Both fine and large print became blurred.</li> </ul> </li> <li>As viewing angle increased <u>further</u> <ul style="list-style-type: none"> <li>Image blurred and "washed out" as if obscured by fog.</li> </ul> </li> </ul>	Top to bottom: <ul style="list-style-type: none"> <li>40 degrees</li> </ul> Left to right: <ul style="list-style-type: none"> <li>60 degrees</li> </ul> All diagonals: <ul style="list-style-type: none"> <li>35 degrees</li> </ul>
D	Panel Received from Seller	Substantially the same as Exhibit C	<ul style="list-style-type: none"> <li>Substantially the same as Exhibit C</li> </ul>

Figure 7  
Examination results.

PC was set to display a graphic image that included large and fine print, an intricate pattern of lines, and a wide range of subtly varying colors. For each LCD screen, the these procedures were followed:

1. Connect LCD screen to the test fixture.
2. Verify that the LCD screen shows the chosen image.
3. Allow 20 minutes for the LCD screen to warm up.
4. Observe and subjectively judge screen appearance from several positions and angles without using any equipment.
5. Using viewpoint control fixture, in all four directions (up, down, left, and right) increase the angle until one of the following occurs:
  - a. Screen color and general appearance noticeably degrade.
  - b. A graphical pattern of lines begins to distort.
  - c. Fine print readability degrades.

### Investigation Summary

The results of examining and measuring the four Exhibits are tabulated in **Figure 7**. Results show that the video screens fell into two distinct categories: wide and narrow viewing angles. Those with narrow viewing angles do not meet the published specification.

The similarity of results for Exhibits A and B and the similarity of Exhibits C and D suggest that Exhibits C and D might have been mislabeled. Destructive testing to examine the dimensions of the polarizing lines in the LCD screen polarizers was not done.

### Trial

After the expert report was submitted, the case went to trial. A demonstration to compare the video screens was designed, and the components were purchased. The kit consisted of:

- A portable folding table with a non-metallic table-top surface.
- A brand-new tablet computer with a VGA output.

- An ESD protective field service kit.
- A “splitter” cable to run two video screens from one video source.
- The original and a second LCD screen test kit. (Using two LCD screen test kits, a simultaneous demonstration of two screens is possible.)
- The four previously tested video screens.

At trial, during a short recess, the author assembled the demonstration components, such that the LCD screens, the screen test kits, the tablet computer (providing several video images), onto an electro-static-discharge resistant covering over the folding table. The computer displayed identical video onto the two screens. The judge remarked on the obvious difference between the two screens.

### Conclusions

- Thin-film transistor liquid crystal diode video screens can be manufactured to specifications with respect to viewing angle width.
- There was a mix of wide and narrow viewing angle screens delivered by the seller to the buyer.
- The narrow viewing angle screens did not meet published specifications and were inappropriate for the buyer’s application.
- The author’s demonstration and testimony effectively convinced the court of the inadequacy or the defective screens for their expected application.

### References

1. A. J. De Vaan, “Competing display technologies for the best image performance,” *Journal of the Society for Information Display*, vol. 15, no. 9, pp. 274-279, 2012.
2. Y. Takakazu and M. Tomoo, “Industrial LCD Display Modules,” *NEC TECHNICAL JOURNAL*, vol. 2, no. 3, pp. 71 - 74, March 2007.
3. Wikimedia Commons contributors, “TN display closeup 300X,” *Wikimedia Commons*, the free media repository., 5 April 2015. [Online]. Available: [https://commons.wikimedia.org/w/index.php?title=File:TN\\_display\\_closeup\\_300X.jpg&oldid=155983749](https://commons.wikimedia.org/w/index.php?title=File:TN_display_closeup_300X.jpg&oldid=155983749). [Accessed 19 June 2018].

4. Wikimedia Commons contributors, "Color TFT-LCD Layout," Wikimedia Commons, the free media repository., 9 July 2016 . [Online]. Available: [https://commons.wikimedia.org/w/index.php?title=File:Color\\_TFT-LCD\\_Layout.png&oldid=201136945](https://commons.wikimedia.org/w/index.php?title=File:Color_TFT-LCD_Layout.png&oldid=201136945). [Accessed 19 June 2018].
5. Wikimedia Commons contributors, "Color TFT-LCD Cells-Schematic," Wikimedia Commons, the free media repository., 21 October 2016 . [Online]. Available: [https://commons.wikimedia.org/w/index.php?title=File:Color\\_TFT-LCD\\_Cells-Schematic.png&oldid=210429248](https://commons.wikimedia.org/w/index.php?title=File:Color_TFT-LCD_Cells-Schematic.png&oldid=210429248). [Accessed 20 June 2018].
6. J. Stohr and M. G. Samant, "Liquid crystal alignment by rubbed polymer surfaces: a microscopic bond orientation model," *Journal of Electron Spectroscopy and Related Phenomena*, Vols. 98-99, p. 189-207, 1999.
7. NEC LCD Technologies, Ltd., Data Sheet: TFT Color LCD Module, NEC LCD Technologies, Ltd., 2007.
8. EIZO Corporation, "The difference in image quality is perfectly obvious! - Let's check the LCD's display," EIZO Corporation, 2018. [Online]. Available: [http://www.eizoglobal.com/library/basics/difference\\_in\\_image\\_quality/index.html](http://www.eizoglobal.com/library/basics/difference_in_image_quality/index.html). [Accessed 22 June 2018].
9. International Committee for Display Metrology (ICDM), "<https://vesa.org/vesa-standards/>," Society for Information Display, 1 June 2012. [Online]. Available: <https://vesa.org/vesa-standards/>. [Accessed 22 June 2018].
10. R. Barczyk, B. Kabzinski, D. Jasinska-Choromanska and A. Stienss, "Measuring of the Basic Parameters of LCD Displays," *Journal of Automation, Mobile Robotics & Intelligent Systems*, vol. 6, no. 1, pp. 46-48, 2012.
11. E. Lee, J. H. Chong, S. A. Yang, H. J. Lee, M. Shin, S. Y. Kim, D. W. Choi, S. B. Lee, H. Y. Lee and B. H. Berkeley, "Improved Angle-of-View Measurement Method for Display Devices," *Journal of Information Display*, vol. 11, no. 1, pp. 17 - 20, 2010.
12. R. M. Luo and C. Li, "CIECAM02 and Its Recent Developments," in *Advanced Color Image Processing and Analysis*, New York, Springer, 2013, pp. 19 - 58.
13. R. Soneira, "16 Misleading Display Specs and What They Really Mean," GIZMODO, 20 August 2012. [Online]. Available: [https://gizmodo.com/5936192/\[object%20Object\]](https://gizmodo.com/5936192/[object%20Object]). [Accessed 22 June 2018].
14. S. Fallon, "New LCD Display From NEC Can Switch Between Wide and Narrow Viewing Angles," Gizmodo, 7 October 2007. [Online]. Available: [https://gizmodo.com/314799/\[object%20Object\]](https://gizmodo.com/314799/[object%20Object]). [Accessed 25 June 2018].
15. NEC LCD Technologies, Ltd., "TFT Color LCD Module NL6448BC33-53 Data Sheet," January 2007. [Online]. Available: <http://www.farnell.com/datasheets/68814.pdf>. [Accessed 25 June 2018].
16. NEC LCD Technologies, Ltd., "TFT Color LCD Module NL6448BC33-54 Data Sheet," March 2003. [Online]. Available: <http://www.beyond-infinite.com/lcd/Library/Nec/NL6448BC33-54.pdf>. [Accessed 25 June 2018].
17. LCD Parts, "LST03-V3 LCD Screen Tester," LCD Parts, 2013. [Online]. Available: <http://www.lcdparts.net/LST03.aspx>. [Accessed 25 June 2018].
18. LCD Parts, "LCD Screen Wire Harness," LCD Parts, 2013. [Online]. Available: <http://www.lcdparts.net/WHSDetail.aspx?ProductID=3949>. [Accessed 25 June 2018].