

Journal of the
National
Academy OF
Forensic
Engineers[®]



<http://www.nafe.org>

ISSN: 2379-3252

Vol. 36 No. 1 June 2019

Dynamic Motion Simulation: Application in Forensic Engineering

By Mark R. Webster, PE (NAFE 868M)

Abstract

A worker was injured when a large sculpture overturned while it was being transferred on a wheeled cart from a delivery truck onto a dock lift. This paper introduces the use of dynamic motion simulation (DMS) software as a forensic engineering tool for analyzing and simulating motion/contact between multiple interacting physical objects. Important inputs to the software include the mass properties of the objects — in this case, a very irregularly shaped sculpture. For simple shapes, the distribution of mass can easily be approximated by manually discretizing the object into several smaller, simpler shapes. Accurate determination of the mass distribution of an irregular shape (such as a sculpture) can be aided by measurement methods such as the laser scanning process used in this case. The resulting scan data was used to create a 3-D computer model that was processed using conventional mechanical computer-aided design (CAD) and DMS software to determine the mass properties and ultimately to simulate the dynamic motion.

Keywords

Dynamic motion analysis, stability analysis, laser scanning, motion simulation, multi-body physics, forensic engineering

Introduction

This paper introduces the use of dynamic motion simulation (DMS) software in forensic engineering applications, specifically for use when investigating incidents involving complex free motion and contact between multiple physical objects. The case selected to illustrate the usefulness of DMS software involves an incident that occurred while employees were moving a large sculpture (which had been strapped onto a wheeled cart) across a pair of aluminum dock plates depicted in **Figure 1** and onto a hydraulic dock lift at an art museum loading dock. Dock plates, which are routinely used to span the gap

between a truck and a loading dock, are rated for a maximum deviation in height between the two surfaces, depending on the dock plate model. The dock plates used during this incident were rated for a maximum 5-inch deviation. During the process of negotiating across the dock plate and onto the dock lift, the sculpture toppled, landing on one of the workers and causing significant injuries. **Figure 2a** and **2b** on page 2 show the position of the sculpture and dolly after the incident.

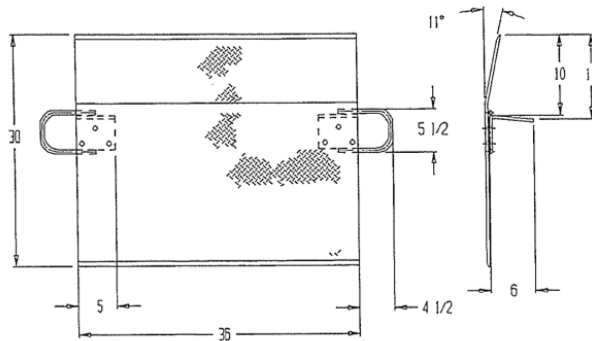

Figure 1
Dock plate.



Figure 2a
Position of sculpture after incident.



Figure 2b
Position of sculpture after incident.

The sculpture was mounted to the four-wheeled cart depicted in **Figure 3** and visible in **Figure 2b**. The front of the cart was fitted with caster wheels, which swiveled to allow the cart to be steered. Wooden blocking had been included as part of the cart design and was bolted to the cart to keep the sculpture centered. The cart was moved out of the truck and down the dock plates back first, with the caster wheels on the trailing end. Three employees were involved in the move. Two were inside the truck pushing the sculpture out, while a single employee was crouched behind the sculpture, attempting to control the speed of travel down the inclined dock plates by applying hand pressure on the leading edge of the cart.

No testimony provided any indication of the magnitude of any external forces applied by the workers. It was indicated that any force applied to either end of the sculpture was applied to the wooden cart or blocking — not the sculpture itself because direct contact with the sculpture was not permitted. As will be discussed later in the paper, any force that the worker was able to apply low on the rear (leading end) of the cart would have had little effect on

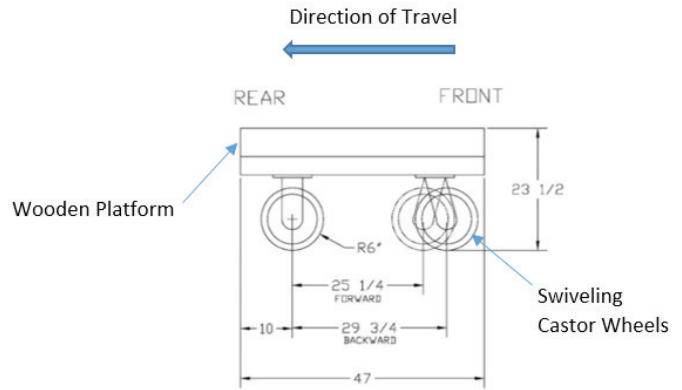

Figure 3
Cart geometry.

either slowing the travel speed of the sculpture down the incline or preventing it from toppling.

The pry bar seen in **Figure 2a** was used to free the trapped worker after the incident. There was no evidence presented indicating one of the dock plates was displaced as is shown in the photos, so it is assumed it was moved manually after the incident. These photos (as well as others taken at the scene) show that the sculpture fell straight backward, without any significant rotation about the vertical axis. This supports using a 2-D analysis.

Dynamic Motion Simulation Software

Using a computer model of a system of physical bodies, DMS software determines the equations of motion for all the bodies in the analysis, comprised of the force-balance equations, velocity equations, and constraint equations. The software solves this system of equations through iterative methods, such as Adams-Moulton and Adams-Bashforth¹. To assist the reader in appreciating the scope of computations, **Figure 4** presents a typical, generic set of eight equations containing unknowns for a simple 2-D pendulum — a simple model. Each body in the analysis has a similar set of coupled equations that must all be solved simultaneously at each small incremental time step to determine the position, velocity, and acceleration of each object.

$$\left. \begin{aligned} m\ddot{u} + \lambda_1 \\ m\dot{v} + \lambda_2 + mg \\ I\dot{\omega} + \lambda_1\ell \sin \theta - \lambda_2\ell \cos \theta \\ \dot{x} - u \\ \dot{y} - v \\ \dot{\theta} - \omega \\ x - A_1 - \ell \cos \theta \\ y - A_2 - \ell \sin \theta \end{aligned} \right\} = 0.$$

Figure 4
2-dimensional equations of motion.

of free bodies are based on Newton's laws of motion and have been known since the late 18th century. However, these theories were too complex to be applied to anything other than simple problems until the advent of the computer. By applying these methods using modern computers, DMS software can solve motion problems with a virtually unlimited number of degrees of freedom, and such software is widely used in many areas of engineering design, testing, and education.

In the practice of forensic engineering, DMS software can be used to calculate and visually simulate the motion of physical objects, including impact with each other. The resulting simulation is not just a "cartoon," but rather is based on laws of physics. Educating the jury on this fact will help give them confidence that the results are reliable and credible. A detailed discussion of these theories and the iterative numerical methods used is beyond the scope of this paper.

Analysis

It was of interest in this case to gain an understanding of the motion of the sculpture at the time of the incident as well as the role instability of the sculpture played on the wheeled cart. To accomplish this, a combination of graphical methods and DMS software analysis was used to determine the static (stationary) stability and the dynamic (in motion) stability under a variety of conditions — and the circumstances that result in instability.

The static analysis will simply determine the angle of incline, corresponding to a difference in elevation between the front and rear wheels, that causes static instability. Since it is known that the sculpture was in motion at the time of the incident, the angle of static instability is useful for reference only, although it is interesting to compare it to the angle at which dynamic instability occurred. The results of the analysis showed that the stability of the sculpture was significantly reduced when it was in motion across the inclined dock plates when they were used within the height deviation as published by the manufacturer.

As the rear wheels started down the ramp, the front wheels were still on the level surface of the truck bed. As the sculpture continued to move down the incline, the rear wheels continued to drop while the front wheels continued on the level surface. This caused the sculpture to rotate at a rotational velocity (ω) that was roughly proportional to the linear velocity (V) of the center of gravity of the sculpture. The rotating sculpture had a resulting rotational kinetic energy equal to $\frac{1}{2}I\omega^2$, where I is the mass moment of inertia

of the sculpture.

When the rear wheel exited the ramp, the sculpture would have stopped rotating. However, the rotational kinetic energy tended to keep the sculpture rotating (**Figure 5**) and caused the sculpture to become dynamically unstable at a lesser angle than the angle of static instability. The rotational velocity of the sculpture — and the resulting rotational energy — was directly related to the speed at which the sculpture rotated down the incline. For example, as the velocity of the sculpture approached zero, the angle of dynamic instability approached the angle of static instability, since the rotational kinetic energy would have also approached zero. As the travel speed, rotational speed, and rotational energy increased, the angle at which dynamic instability occurred was reduced. Since any external forces or initial velocity that existed would have caused the sculpture to become unstable at a lesser incline, it was a conservative approach to leave external forces and initial velocity out of the analysis.

Manual calculation of the simple rotation of the sculpture (as described above) using the energy method or another method was feasible. However, due to the iterative approach and the desire to vary certain variables, such as externally applied forces and initial velocity, this process would have been extremely time-consuming compared to the DMS software approach. It was, however, desirable to perform a single calculation that could be compared to a result from the DMS software for specific parameters as a check of the accuracy of the computer model.

One advantage of DMS software is the ability to quickly perform multiple analyses to test the effect of varying parameters, such as the speed and angle of incline, as was done in this case. DMS software is also particularly useful for evaluating motion involving con-

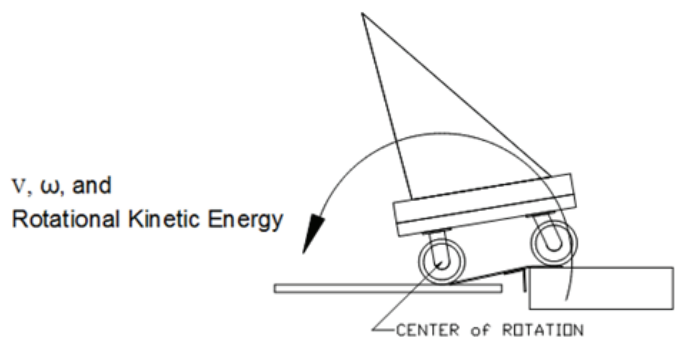

Figure 5
Rotational velocity and kinetic energy.

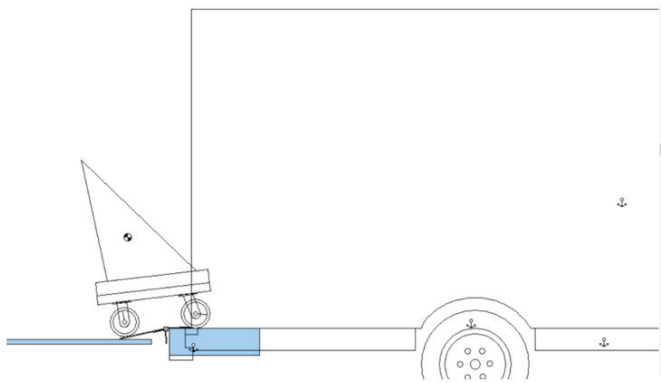

Figure 6
Unloading geometry.

tact between objects with complicated shapes, such as the wheels traveling over the dock plate. As shown in **Figure 6**, as the sculpture was traveling down the incline, the trailing wheels contacted the tapered lip on the front edge of the dock plate. Depending on the sculpture velocity at that moment, the wheels were forced quickly upward, causing increased angular velocity and rotational kinetic energy. To compound matters, the spacing between the wheels (29¾ inch; see **Figure 3**) nearly matched the 30-inch length of the dock plate (**Figure 1**). This meant the front wheels were rising at nearly the same moment the rear wheels were dropping — again increasing the rotational velocity and rotational kinetic energy. All of this motion was calculated and simulated by the software, and would have been very tedious to calculate manually.

The power of DMS software allows the user to individually vary the values of factors, such as the angle of incline (difference in height between the truck and the dock lift), initial velocity, mass properties, external forces, etc., and observe the effect of each on the analysis. Since the actual values of these factors were unknown, this experimental process was valuable in determining which variables were most important — and whether excluding them from the analysis would yield conservative results. As expected, the results indicated that any initial velocity would have decreased stability, and any forces applied by the workers would not have significantly reduced the speed of the sculpture or prevented it from toppling. Thus, the analysis is conservative (indicating a larger angle of instability than actual) with these factors left out of the analysis.

The purpose of this paper is to introduce both the use of DMS software in forensic engineering applications and a method for obtaining the important mass properties of an irregularly shaped object. It is not intended as a

rigorous evaluation of the underlying mathematical theories. It is assumed that the reader has a basic understanding of kinematics and dynamics. It is imperative that the user of DMS software is properly trained in its use, and is able to perform manual calculations using basic concepts such as those discussed above (when practical) to validate the accuracy of the computer model.

Determining the Mass Properties

To perform an analysis of the static stability of the sculpture, knowledge of the weight and location of the center of mass of the sculpture/cart assembly, as well as the physical geometry of the wheeled cart, was required. To perform an accurate dynamic motion analysis of the sculpture moving across the various surfaces, the mass moments of inertia of the sculpture and cart assembly about all axes of rotation were also required.

To determine the mass properties of the sculpture, it was necessary to mathematically describe its distribution of mass. A manual approximate method of doing this is to break down the object into smaller pieces, and approximate the shape and dimensions of each piece. The mass properties of each piece are then calculated and summed together to determine the mass properties of the entire object. The random shape of this sculpture made it very tedious to obtain a good approximation of the mass properties through hand measurements and calculations. Additionally, direct physical contact with the sculpture was not allowed, making it difficult to perform accurate measurements through manual methods.

A number of non-contact methods to measure the sculpture and create a 3-D surface model were evaluated and narrowed to two technologies: photogrammetry³ and laser scanning. Both technologies perform the task of creating an electronic point cloud of data representing the surface of the sculpture. The point cloud is then processed with specialized software to create a solid model and calculate the mass properties of the sculpture. Photogrammetry is a technique whereby multiple photos of an object from multiple angles are processed by specialized software to calculate the surface geometry of the object.

Although the photogrammetry method would likely yield data accurate enough to give a good approximation of the sculpture mass properties, there would be no way to verify that at the time the photographs were taken. If additional photos were needed, requiring a return trip to the museum, the cost could end up exceeding the cost of laser scanning. The results of laser scanning, on the other hand,

can be viewed graphically at the time of the scan to verify the results, plus the accuracy of laser scanning is superior. Based on these differences, it was decided that the higher cost of the laser scan was justified in this case.

An engineering firm in Detroit was commissioned to scan the sculpture with a laser to create a 3-D computer model of the surface of the sculpture in the form of a point cloud. A total of 164 scans were performed at various angles to ensure all of the surface details were captured. The scan setup is shown in **Figure 7**. The methodology and steps followed are illustrated in **Figure 8**. The point cloud was then converted into a raw surfaced model — a stereo lithography (.STL) file⁴ — containing 3.7 million triangles. Since a file of this size would be time consuming to process, Geomagic software was used to “decimate” the .STL files, resulting in five new STL files ranging in size from 50,000 to 2,000,000 data points. The decimation keeps the points more dense around the high curvature

areas, but reduces the density of points for flat, low-curvature areas. These reduced surfaced models were evaluated for quality by importing into SolidWorks⁵ 3-D solid modeling software and viewing them. Even the smallest 50,000 point surface model was of good quality, so it was chosen as the file to proceed with. The resulting surface model is shown in **Figure 9**.

The center of gravity and volume could be easily calculated from the .STL file by various software. However, to ensure an accurate motion analysis, it was also desired to know the mass moments of inertia of the sculpture so that rotational dynamic effects could be included. SolidWorks⁶ software was used to calculate the weight and mass moments of inertia (**Figure 10** on page 6). For SolidWorks to calculate these values, the .STL file needed to be converted into a “watertight” surface model (i.e., no holes). Geomagic software was again used to convert the .STL file into a NURBS⁷ surface file (in .IGS format), which was imported into SolidWorks and converted into a 3-D solid model.

The precise mass density of the sculpture material



Figure 7
Scanning setup.

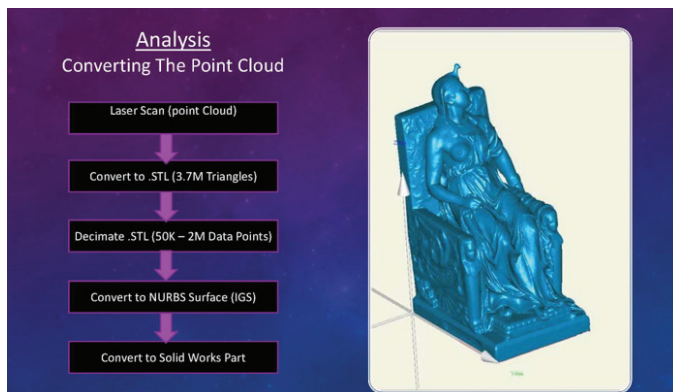

Figure 8
Point cloud processing methodology.



Figure 9
Decimated STL surface mesh.

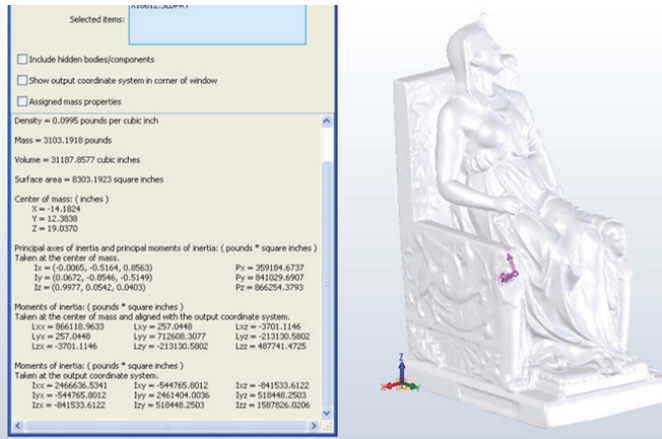

Figure 10
Mass properties.

was unknown (indicated only as “marble”). Since physical contact with the sculpture was not allowed, it was not possible to weigh it. However, the weight of the sculpture was consistently documented at approximately 3,100 pounds in case documents. The volume of the sculpture was precisely determined to be 31,188 inch³ through laser scanning. If it could be shown that a value of mass density for marble that results in a calculated weight of 3,100 pounds for the measured volume falls within the range of published values, then it could be assumed that the sculpture material was homogeneous, consisting of relatively uniform material with no significant internal voids.

The value for mass density of the sculpture material used in the SolidWorks model was adjusted until the calculations yielded a weight of approximately 3,100 pounds based on a volume of 31,188 inch³. The mass density value that yielded the reported weight of the object was 0.100 pounds/inch³. This value of mass density falls within the 0.094 - 0.101 pounds/inch³ range of densities for marble as listed on several online sources^{8,9,10}. The fact that the calculated density fell near the upper range of published densities made it even less likely that there were voids or significant density variations within the sculpture.

All indications were that the marble sculpture material was of consistent density, with no internal voids, which is typical of marble chosen for sculpting. Based on this, it is reasonable to assume that any existing variation in density would not have a significant effect on the calculated mass moment of inertia of the sculpture or the results of the dynamic analysis. Damage to the sculpture as a result of the incident was limited to a hand breaking off. The damage was repaired prior to scanning, so the resulting model represented the geometry of the sculpture as it existed at the

time of the incident.

The cart was made available for measurements, but not testing. Consequently, the weight of the cart was determined to be approximately 248 pounds by physically measuring it and calculating the weight using the average density for hardwood (oak and maple) as published in the *Building Design and Construction Handbook*¹¹. A representative manufacturer’s published weight was included for the wheel assemblies. The center of gravity of the cart assembly was then manually calculated based on the measured geometry. Documents released by the art museum (indicating a cart weight of approximately 251 pounds) verified these results.

The location of the sculpture on the cart is important to the analysis, and was controlled by wooden blocking that was incorporated into the cart design. The blocking ensured that the sculpture was centered on the cart and would not shift during transport.

2-D vs. 3-D Analysis

Various software is available to perform a dynamic analysis in three dimensions based on a 3-D solid model. There is also software available that will perform a 2-D dynamic analysis, which may be appropriate when the motion is restricted to single plane (2-D motion), and all moving solid bodies in the analysis exhibit mass symmetry about this plane of motion (**Figure 11**). A 2-D analysis is computationally less strenuous than a 3-D analysis because each body has only three degrees of freedom vs. six

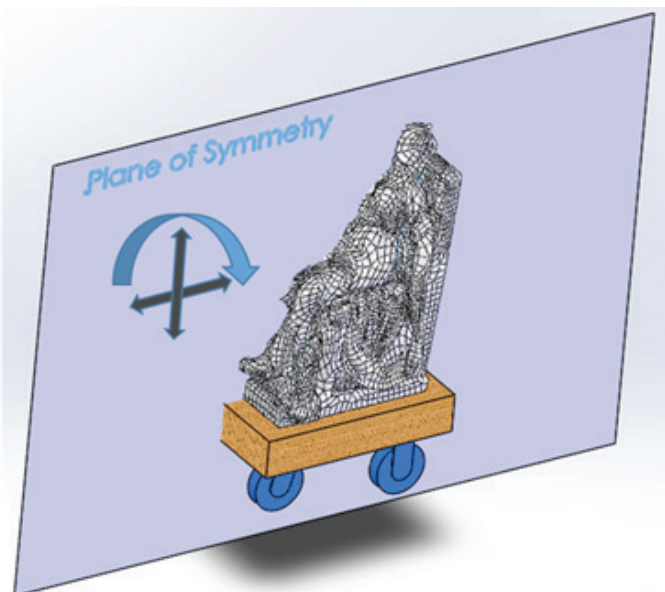

Figure 11
Plane of symmetry and plane motion.

for a 3-D analysis. This reduces the time and computer resources required, particularly when multiple analyses are performed to determine the effect of varying input parameters, as discussed earlier.

Based on testimony from eyewitnesses to the accident, the sculpture toppled straight backward as it traveled from the dock plate to the dock lift. This was supported by the post-accident photos (**Figure 1**), which show that the sculpture did not rotate significantly to the side when it toppled. Additionally, the center of gravity of the sculpture in the global x-axis direction (width) was calculated to be approximately $1\frac{3}{8}$ inches from the dimensional center. In a 3-D motion analysis, this offset would affect the amount of rotation generated about the global z-axis (vertical axis) due to dynamic effects. It was decided that the relatively small offset of the center of gravity in the x-axis would not significantly affect the resulting motion, and a 2-D planer analysis would accurately calculate the dynamic motion. Friction between the four wheels and the surfaces they were riding on would also resist this rotation of the sculpture about the vertical axis.

Dynamic vs. Static Stability

An analysis of the stability of the sculpture while at rest (static) was simple to calculate once the mass properties were known. Static instability occurred when the center of mass was vertically aligned with the rotation point of the sculpture (the gravitational line of force passed through the center line of the leading wheel axles.) At the point of instability, any additional rotation or momentary force on the sculpture in the direction of rotation will cause the sculpture to topple.

Dynamic instability occurred when the sculpture was in a state of motion where it was destined to topple, void of any additional external forces. An analysis of the dynamic stability of the sculpture while traveling over an uneven surface is complex.

To perform such an analysis manually, it was necessary to determine all of the various equations of motion for the sculpture over the entire period of the movement, and then solve them simultaneously. Manually determining the motion in this manner was not practical for the problem at hand, particularly when multiple calculations were desired to determine the effect of varying the input parameters. Dynamic analysis software, however, could determine all the equations of motion and solve them for each incremental moment in time. The resulting calculated positions of the sculpture could then be displayed graphically and

played back in sequence to simulate the calculated movement.

As the moving sculpture negotiated across the dock plate onto the dock lift, dynamic forces were generated that tended to topple the sculpture at a lesser angle of inclination than that of static instability. During the analysis, the deviation in height between the truck bed, the dock lift surface, and the resulting angle of inclination of the dock plate were varied until the sculpture became dynamically unstable and toppled. The actual height deviation at the time of the incident was unknown. The purpose of the analysis was to determine whether the sculpture was unstable when moving over the dock plates when there was a reasonable, normally expected difference in height between the truck bed and the lift surface. The manufacturer of the dock plates used recommended a maximum height deviation of 5 inches.

Calculating the Static Stability

AutoCAD software was used to create a 2-D model of the sculpture and cart that accurately described the geometry, including the position of the center of gravity of the sculpture/dolly assembly as determined above. The model was then rotated graphically until the line of action of the center of gravity aligned with the axis of rotation — the center of the leading wheel axle. This corresponds to the angle at which the sculpture is statically unstable. In this position, any further rotation or small force applied to the sculpture will cause it to topple due to it being unstable.

This analysis was performed in both directions, calculating the static stability as if the sculpture was negotiating a ramp moving forward as well as backward. When moving backward, the distance between the front and rear wheels was reduced when the caster wheels pivot toward the rear. The difference in height between the front and rear wheels in this position was measured and recorded, indicating the angle at which the sculpture became statically unstable. **Figure 12** on page 8 illustrates that when the sculpture was facing backward (the direction of travel during the accident), this equated to a difference in height between the front and rear wheels at static instability of approximately $6\frac{1}{2}$ inches, corresponding to an inclination angle of 13 degrees. **Figure 13** on page 8 illustrates that if the assembly is turned around as if the front was facing down the slope, the difference in height between the front and rear wheels at the point of instability is approximately 11 inches with a corresponding inclination angle of 27 degrees. Thus, it takes more than twice the angle of inclination to create static instability when the sculpture is traveling face first as

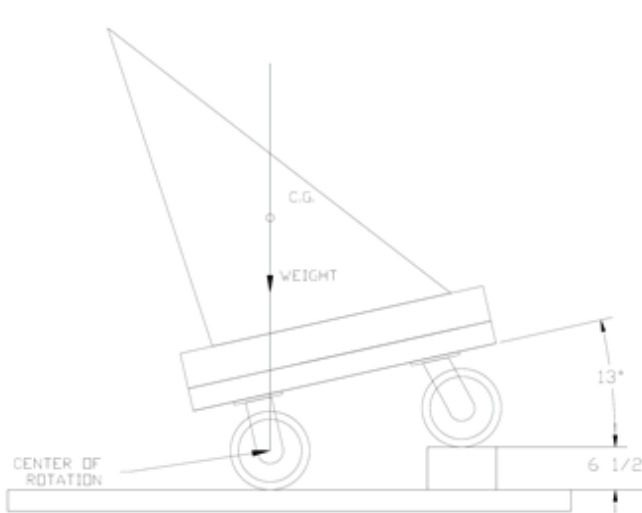

Figure 12

Inclination at static instability moving back-first.

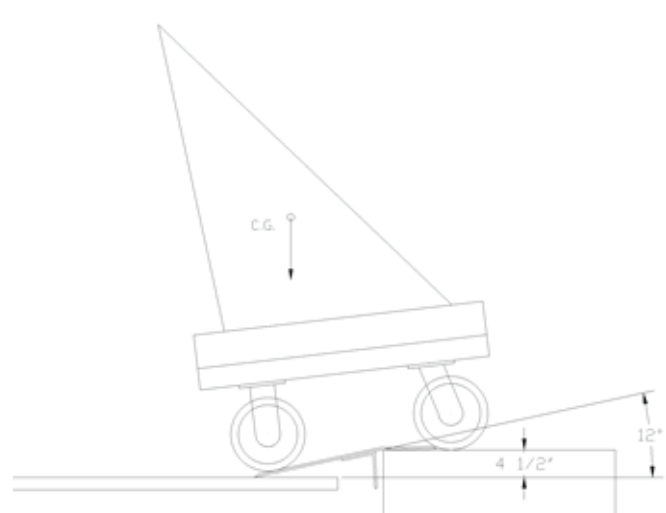

Figure 14

Dynamic analysis initial position.

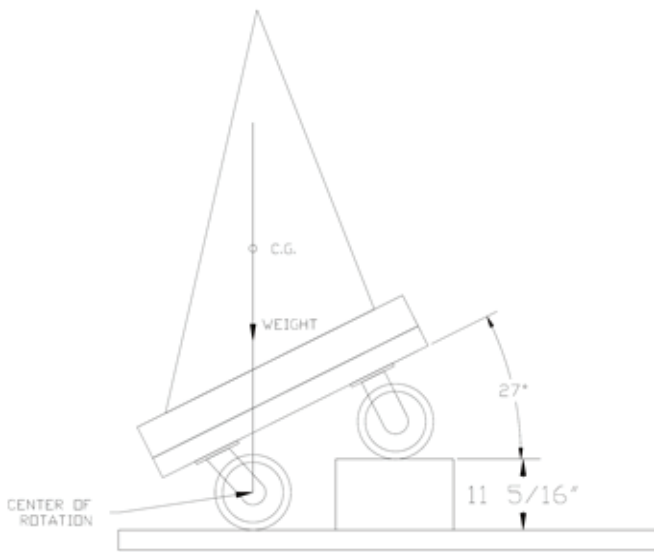

Figure 13

Inclination at static instability moving front-first.

opposed to traveling backward.

Calculating Dynamic Stability

Working Model^{12,13}, DMS software was used to perform a 2-D dynamic analysis. A geometrically representative model was created within the software, and the previously calculated mass properties of the sculpture and dolly were input as properties of a triangular-shaped object representing the sculpture for simplicity.

The profile of the aluminum dock plates and two surfaces representing the lift platform and the truck bed were also included in the model. Surface to surface contact was set between the wheels and all surfaces they come in contact with (truck bed, dock plates, and dock lift surface).

A friction coefficient was determined through testing of similar exemplar wheels, and was applied to the rotational constraint representing the rolling friction of wheels on their axles in the model.

The DMS analysis was performed multiple times, each time increasing the difference in elevation between the truck bed and the dock lift surface, which also increases the angle of the dock plates spanning the two surfaces. The initial speed of the sculpture was then increased incrementally and observed to incrementally decrease the calculated angle of instability (less stable). To be conservative, the initial velocity was set to zero for the analysis. The initial position of the sculpture was set to the point where the trailing wheels were in contact with the lip of the dock plates as shown in **Figure 14**. The minimum elevation deviation between the truck bed and the dock lift surface at which the sculpture topples defines the minimum angle of dynamic instability.

Figure 14 depicts the initial position of the sculpture used for the analysis. It also illustrates the results of the analysis — that a 4½-inch variation in height between the truck bed and the lift platform (resulting in a 12 degree inclination of the dock plates) was sufficient to create instability and toppling of the sculpture as it traveled over the dock plates and onto the lift platform under the conservative initial conditions described above. This is in contrast to the 6½-inch deviation that was calculated to result in static instability. Once the point of instability was reached, personnel moving the sculpture would be unable to prevent it from falling backward onto the lift.

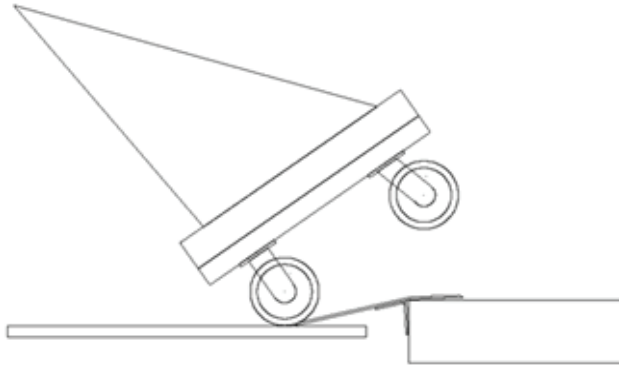

Figure 15
Dynamic analysis intermediate position.

This was verified by incrementally increasing the force applied to the leading edge of the cart by the single worker trying to control the speed. Even an unrealistic force of 300 pounds horizontally would not have prevented it from toppling when the trailing wheels contacted the lip of the dock plate as described earlier. **Figures 15 and 16** show an intermediate position and the final position of the sculpture. These results are conservative, since the initial velocity of the sculpture was assumed to be zero. Any initial velocity would have decreased the required deviation in height that results in dynamic instability.

Literature from dock plate manufacturers indicates that a 36-inch-long dock plate, such as those being used at the time of the accident, were usable for height deviations of up to 5 inches. The dynamic analysis indicates that the geometry of the dolly was unsafe for use in moving the sculpture across the dock plates from the truck to the dock lift because dynamic instability occurred at a deviation in height near that which is considered normal when using the dock plates.

Since static instability occurred at 6½ inches height deviation, moving the sculpture very slowly down the inclined dock plates may have been successful. (Remember, at near zero speed, the dynamic angle of instability approaches the static angle of instability). However, with a height deviation of 4½ inches and a dock plate angle of 12 degrees — and with the sculpture in the position shown in **Figure 14** — the single worker trying to control the speed of the sculpture would not likely be able to do so. The sculpture would pick up speed, become unstable, and topple.

Conclusions

1) The use of laser scanning technology can be an effective measurement method to ensure the accuracy of the

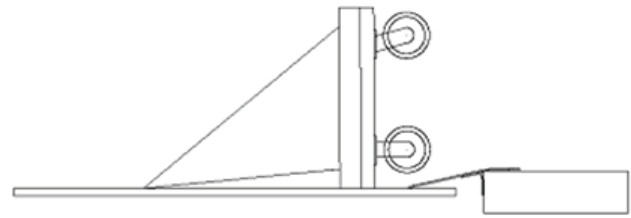

Figure 16
Dynamic analysis final position.

data used to calculate the mass properties of objects for use in stability calculations and dynamic motion simulations.

2) The use of DMS software can be effective for illustrating that the maximum inclination the sculpture could safely navigate was significantly less when the sculpture was in motion vs. stationary on an incline — and that the sculpture was dynamically unstable when traveling across the dock plates even when being correctly used (within the published limits of height deviation of the dock plates).

3) Certain complicated multi-body free motions, including collisions, can be effectively analyzed using DMS software, resulting in a motion simulation based on the principles of physics.

4) With a height deviation near the maximum allowable for the dock plates used, the workers would have been unable to stop the sculpture from toppling due to the dynamic instability of the sculpture.

References

1. McConville J. Introduction to mechanical system simulation using Adams. Mission, KS: SDC Publications; 2015.
2. Greenwood D. Principles of dynamics. Englewood Cliffs, NJ: Prentice Hall; 1965.
3. PhotoModeler Premium. Vancouver BC, Canada: PhotoModeler Technologies; [accessed 2020 July 9] <https://www.photomodeler.com/products/premium/>.
4. STL (file format). San Francisco, CA: Wikimedia Foundation, Inc.; [accessed 2020 July 9] [https://en.wikipedia.org/wiki/STL_\(file_format\)](https://en.wikipedia.org/wiki/STL_(file_format)).
5. GeoMagic for SolidWorks. Rock Hill, SC: 3D Systems, Inc.; [accessed 2020 July 9] <https://>

www.3dsystems.com/software/geomagic-solid-works.

6. SolidWorks. Waltham, MA: Dassault Systèmes SolidWorks Corporation; [accessed 2020 July 9] <http://www.solidworks.com>.
7. What are NURBS? Seattle: Robert McNeel & Associates; [accessed 2020 July 9] <https://www.rhino3d.com/nurbs>.
8. Engineering ToolBox, (2009). Density of Selected Solids. [online] Available at: https://www.engineeringtoolbox.com/density-solids-d_1265.html [accessed 2015 Dec 7]. Density of marble listed as 0.094 lb./in.³ to 0.101 lb./in.³.
9. Density of Marble [CaCO₃], <https://www.aquacalc.com/page/density-table/substance/marble>, AVCalc LLC, 2020. Density of marble listed as 0.098 lb./in.³.
10. Density of Materials, <https://amesweb.info/Materials/Density-Materials.aspx>, AMES, 2020. Density of marble listed as 172.9 lb./ft.³ (0.100 lb./in.³).
11. Merritt F. Building design and construction handbook, 4th edition. New York, NY: McGraw Hill; 1982.
12. Working Model 2D, Version 9, Design Simulation Technologies, 2013.
13. Working Model 2-D. Canton, MI: Design Simulation Technologies; [accessed 2020 July 9] <https://www.design-simulation.com/wm2d/>.