

Journal of the
National

Academy OF

Forensic

Engineers[®]



<http://www.nafe.org>

ISSN: 2379-3252

Forensic Engineering Investigation of Vehicle Hub Separations

by John Leffler, P.E. (NAFE 709S)

Abstract

Separation of a wheel-hub assembly from a moving vehicle can have catastrophic consequences. Commercial tractor trailer wheel-hub assemblies in particular may weigh several hundred pounds. Bearings, lubrication, sealing, brakes, assembly, usage, and maintenance may each play a part in a wheel-hub separation. Two forensic cases will be discussed regarding wheel-hub separations from a consumer cargo trailer and from a commercial gravel trailer.

Keywords

wheel, hub, bearing, brake, axle, seal, forensic engineer

Introduction

Vehicle manufacturers nominally have responsibility for safety-related defects in their vehicles and in original-equipment attachments, per Federal regulations. Each assembly of wheel, tire, hub, and brake comprises one of the rotating interfaces between the vehicle and the road. As these assemblies must withstand potholes, curbs, submersion, thermal shocks, and millions of rotations, the components are typically substantial and heavy. If the mechanical integrity of the means of rotation is compromised, the hub may separate from the axle, carrying the other attached components with it. The hub and attachments on a small utility trailer or economy car may weigh “only” 20 pounds, while a heavy truck tandem axle may carry spoked cast hubs with dual wheels/tires and a large brake drum – which together may weigh over 500 pounds. With the momentum imparted to these rotating assemblies by highway travel speeds, it is easy to predict that impact of a separated hub into another vehicle can be disastrous.

This paper will discuss a variety of disparate issues that were considered in the investigation of two forensic cases. One forensic case involved a low-mileage 10,000 pound Gross Vehicle Weight Rating (GVWR) equipment trailer, which experienced a separation of a right-side hub; the assembled hub, drum, wheel, and tire struck a motorcyclist, causing severe injury. Another forensic case involved a commercial gravel trailer (50,000 pound GVWR) that experienced a left-rear hub separation, resulting in impact of the separated hub, drum, dual wheels, and tires with a passing light truck. General investigative options for hub separations will also be discussed.

OVERVIEW OF VEHICLE HUB SYSTEMS

Axles

Generally the axle is the fixed component about which the hub rotates – though the term “axle” is used in various ways. For non-driven front suspensions, the axle is typically a short “stub” projecting from the suspension upright or MacPherson strut assembly. Similarly for non-driven rear axles, a “stub” protrudes from each end of the main axle beam or MacPherson strut assembly (for cars), or from the end of the axle tube (for trucks). See Figures 1 & 2.

For driven “solid” rear axles (used on light trucks and most US cars through the mid-1980s), the axle tube will typically be hollow, with a halfshaft rotating within it to drive the hub. Driven front axles are a bit different, in that the typical arrangement involves the hub and constant-velocity joint

(for the halfshaft) rotating within the suspension upright or MacPherson strut assembly – this configuration is also used for driven rear axles with independent suspensions. See Figure 3. Each of these axle configurations prescribes a certain hub bearing configuration; we will use the more common term “wheel bearing”, despite the fact that the wheel does not directly fasten to the bearing.

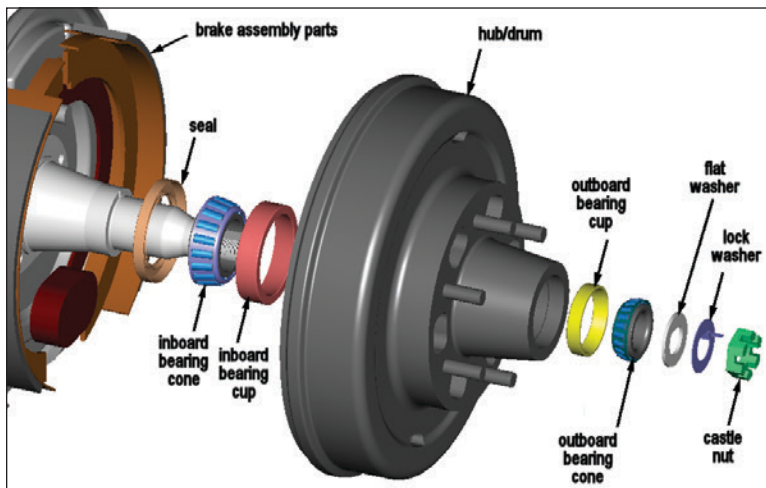

Figure 1

5,200 pound axle capacity trailer hub

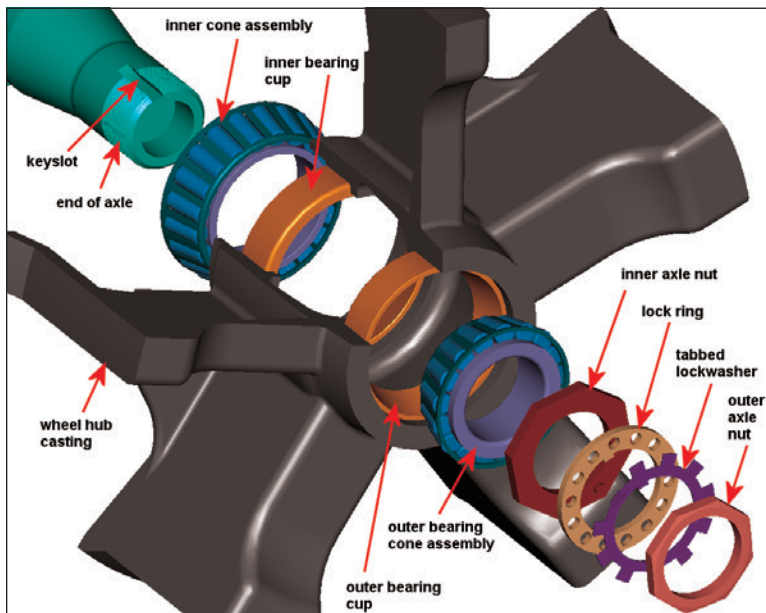

Figure 2

22,500 pound axle capacity trailer hub (brake not shown)



Figure 3

Driven axle hub

Wheel Bearings

The primary cause of hub separations is wheel bearing failure. The failure can be due to many issues, including bearing defects, insufficient lubrication, improper adjustment, wear, and roadway impacts. These issues will be discussed in a subsequent section.

- Common types of wheel bearings

- Tapered roller

- This bearing configuration uses two bearing assemblies per hub – the inboard bearing (towards the vehicle centerline) and the outboard bearing. Often the inboard bearing is larger in diameter and load-carrying capacity than the outboard bearing, as the inboard bearing carries a greater proportion of wheel loads. Refer to Figures 1 & 2.
 - Tapered roller bearings are designed to accommodate both radial and thrust (axial) loading, but must be used in “opposing” pairs, as each bearing assembly can only accommodate thrust loads in one direction.
 - Each tapered roller bearing assembly is a matched set, consisting of an outer race (or “cup”), and an assembly (the “cone”) of an inner race, bearing rollers, and a cage that retains the rollers. See Figures 1 & 2. The contacting surfaces of the rollers and races are hardened, precisely ground, and highly polished, with specific matchings of race and roller angles. Typically the “cone” assembly cannot be readily disassembled.
 - Each hub’s pair of tapered roller bearing assemblies are separated by a specific distance, as shown in Figure 4. Generally there is a benefit to maximizing this distance, within the dimensional limitations of the overall suspension design. With greater separation distance, expectable bearing wear will have a reduced effect on the ability to actually “rock” the hub (and wheel) on the axle – also reducing the potential for rotational imbalance and vibration.
 - Tapered roller bearings typically require periodic maintenance of both adjustment and lubrication, which will be discussed below.

- Unitized sealed tapered roller

- Unitized one-piece tapered roller bearings are a variation on tapered bearings that have both the inboard and outboard bearings directly adjacent to each other, sharing a one-piece outer housing with two outer race surfaces. The inner races are independent and separated by a small gap, to allow preload

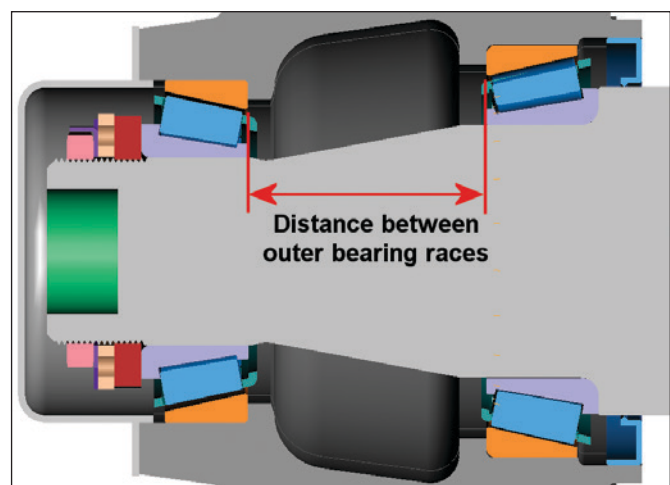

Figure 4

Bearing axial separation – cross-section

adjustment. See Figure 5.

- The separation distance between the unitized bearing races is typically much narrower than for a comparable “paired” tapered roller bearing configuration. As such, even a small amount of bearing wear can result in the ability to noticeably “rock” the hub and wheel on the axle, and this can lead to rotational imbalance, vibration, and skewed roller/race loading that can accelerate further wear. Often axle/vehicle manufacturers will specify that wheels with a particular offset (lateral distance between the wheel’s mounting face and the tire centerline) are to be used with these bearings, in order to align the wheel bearings with the radial wheel loads.

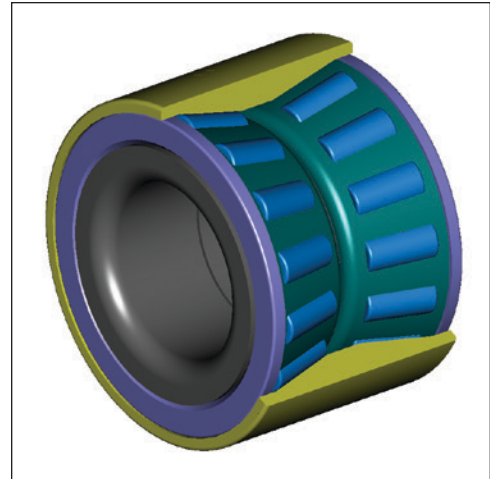

Figure 5
Unitized sealed tapered roller bearing

- The end faces of these unitized bearing assemblies are sealed using polymer-coated sheetmetal discs with flexible radial “wipers” (contacting the inner races) and dust sealing features to keep contaminants out of the lubricant, which is typically a grease prepacked by the manufacturer.
 - Unitized sealed bearings typically do not require periodic maintenance of either adjustment or lubrication – the marketing of such bearings typically focuses on these attributes. However, just as maintenance is not required, preventative inspection is not possible.
- Bearing lubrication
 - Grease: Specialized greases are frequently used for bearing lubrication. The greases must survive long-term high operational temperatures and extreme contact pressures in the bearing surface interfaces, while keeping sufficient viscosity to maintain a film of grease on the frictional surfaces. The sealing of grease-packed hubs is typically intended to keep the grease contained and to keep out dust, solid debris, and splashed contaminants.
 - Grease can be added manually to a bearing or by using a greasing tool. Hand greasing bearings can be time consuming, in terms of ensuring that all the bearing voids are filled.
 - Oil: Rear axles on trucks commonly use an oil bath with tapered roller bearings. This requires effective sealing to keep the oil in and contaminants out.
 - Oil seals: Typical oil-bath hubs use a ring-shaped oil seal that is pressed into the rotating hub casting. The oil seal is typically formed sheetmetal with an overmolded polymer sealing surface and a V-shaped polymer lip that is held (by a garter spring) against a polished cylindrical surface on the fixed axle stub. This oil seal, combined with a sealed hub cap, will nominally retain the oil bath. See Figure 6. Oil-bath hubs are vented to allow for thermal expansion; if the vent clogs, the seal can be damaged by internal pressure

buildup. It is of note that these types of seals are often used on grease-packed tapered roller bearing hubs as well. Especially when removing truck hubs (which are quite heavy), it is easy to bump the seals against the axle end, which may damage the seal. The bearing outer races may also be similarly damaged. There are service tools available for supporting the weight of heavy truck hubs during removal.

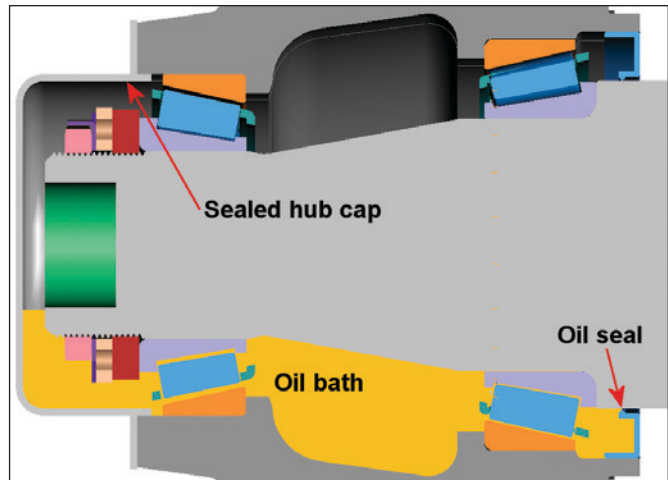

Figure 6
Heavy truck hub with oil bath – cross-section

- Bearing adjustment

- Different combinations of components and materials will necessitate different adjustment methods. As hub/axle components expand dimensionally with operational heating (due to braking and bearing friction), it can be necessary to axially “preload” a certain amount of binding (interference) into the ambient-temperature bearings during servicing, so that when components heat up, the inter-surface gaps are as desired. Such information is provided by the axle or vehicle manufacturer.

- Tapered roller bearings

- These bearings are typically assembled so that gaps between adjacent surfaces are minimized, and as such adjustment is necessary to accommodate wear. The main nut on an axle is typically used to adjust the wheel bearing tightness. Often these accumulated inter-surface gaps are measured using a dial indicator, with a goal of (for example) 0.005" inch of axial relative movement between the axle stub and the hub. Once the bearing gaps or preload is set, a locking feature (cotter pin, bent metal tab, toothed retainer) is typically used on the nut to capture the adjustment. See Figure 7.

- Unitized bearings

- These bearings typically have an axle nut that is torqued to a specified value, which causes the inner races to clamp together with a certain amount of freeplay (or preload). As such, these bearings are not typically adjusted per se.

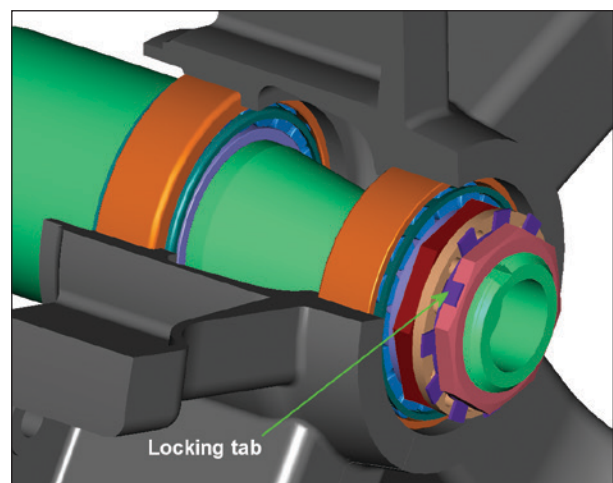

Figure 7
Hub nut locking tab

- Bearing standardization
 - Wheel bearings are typically of standardized configurations, often specified by the American Bearing Manufacturers Association. Dozens of bearing manufacturers around the world create nominally identical bearings according to these standards, and as such the matched cone-cup assemblies are dimensionally interchangeable – though manufacturers recommend that brands not be mixed between a bearing and a race. Generally the bearing designs and load ratings have been well-proven over time.

Selected potential investigative topics for hub separations

- **General design defects:** insufficient engineering factor of safety in the design of component strength for foreseeable loads, tolerance stack-up errors, drawing errors, designed-in stress concentrations, insufficient corrosion prevention or protection, failure to conduct appropriate testing.
- **Material defects:** composition, porosity, voids, grain structure, inclusions, hardness, heat treatment, surface roughness and microfinish, coating formulations and application, lubricant formulations, lubricant incompatibilities, bonding of dissimilar materials in composites, failure to detect such defects through quality control.
- **Component fabrication defects:** tool chatter, welding defects, stress concentrations due to fabrication, casting/forging flash, as-fabricated surface roughness/microfinish, parts out of dimensional tolerance, failure to detect such defects through quality control.
- **Hub / axle joint:** stripped threads in axle nuts or on end of axle stub, failure to use axle nut locking features, failure of axle nut locking features, excessive bearing freeplay or preload, mismatch of bearing components, mixing of new and worn bearing components, improper wheel offset, use of inappropriate aftermarket components.
- **Usage conditions:** overloading of axles, harsh impact usage on atypically rough roadways, usage in unusually abrasive or corrosive environments, water ingress into hubs due to hot submersion, false brinnelling of bearings due to high vibration while stationary, inadequate lubricant volume, careless impact damage to bearings and seals during maintenance/repair, contaminated/overheated lubricant, inadequate preventive maintenance, excessive wear, failures to inspect.

FORENSIC CASE STUDIES

Case #1: Hub separation from 10,000 GVWR flatbed utility trailer

Case facts: A contractor purchased a 2007 dual-axle flatbed utility trailer from a dealer, in October 2007, intending it for use in carrying his 8,000 pound wheeled skidsteer construction vehicle. See Figure 8. The trailer had been manufactured about 100 miles away from the dealer, and was picked up from the manufacturer by the dealer. Four months after purchase, the trailer was being used to haul the skidsteer vehicle from a worksite to the owner's residence. While traveling on an Interstate highway, the right rear hub/wheel/tire assembly separated from the trailer. The assembly ended up striking a motorcyclist



Figure 8
Subject utility trailer



Figure 9
Axle end remaining from hub separation

traveling the opposite direction on the Interstate, causing him permanent injury. The separated assembly was retrieved by the first responders. The right rear axle stub and brake assembly were damaged as the hub separated. Following the incident, the trailer was transported to the owner's residence. See Figure 9.

Case Testimony: According to the owner, the four-month-old trailer had sat at a worksite for several months and had only about 100 miles of use at the time of the incident. Because of this, the owner had not torqued the lugnuts or checked the bearings. Following the hub separation, the owner removed the axle in preparation for replacing it, and contacted the dealer regarding ordering another one. The dealer notified the axle manufacturer about the hub separation, and the manufacturer sent two technical representatives to the owner's residence to inspect the dismantled axle – photographs were taken. Following this, the owner was notified to preserve the trailer, and the damaged rear axle was reinstalled by the owner prior to this author's initial inspection.

Inspection, April 2008

This 2007 model year 10,000 pound GVWR trailer used two 5,200 pound capacity axles fitted with leaf springs and 12" diameter by 2" wide electric drum brakes – each hub has the brake drum integrated as a one-piece machined casting. These axles use grease-packed tapered roller bearings.

In the forthcoming description of components, pseudonyms will be used for the different manufacturer names.

As this is a consumer-grade trailer, the axles are purchased-complete and installed by the manufacturer – the trailer manufacturer doesn't also make the axles. The rear axle, from which the hub separated, was manufactured in 2003 by "Alpha" – four years before the trailer manufacture. Further inspection revealed that the rear axle's hub/drums were the "Bravo" brand (also an axle manufacturer) and the size 12" x 2" brake assemblies (shoes, electric actuators, backing plates) were "Charlie" brand, made in 2006. The rear hub/drum units did not show significant drum wear, consistent with low-mileage use – the brake assembly parts similarly showed light wear. See Figures 10 and 11. The separated hub/drum

had a large chunk broken away, as shown in Figure 12. The wheel was bent and deformed in several areas, and the tire was deflated, though otherwise in apparently good condition.

The axle stub showed evidence of friction superheating, melting, and bending. The axle nut was missing, though damaged portions of the outboard bearing inner race, outboard bearing cage, and axle nut washer were present. The inboard bearing cone and ring-type seal were intact in place on the axle stub. See Figures 13 & 14. The brake shoes were present but were bent on the lower portions, and abnormal wear patterns were observed on the friction surfaces. See Figure 15. The condition of the brake shoes and axle stub end are consistent with the hub/drum partially separating and rolling askew on the axle stub, still somewhat retained, for some distance before complete separation.

The entire front axle assembly was a different “Delta” brand, and manufactured in 2007. No disassembly or other destructive testing was performed at this inspection.

Discovery information

It had been determined that the Charlie rear axle brake assemblies were marketed by the rear axle manufacturer Alpha, starting in 2006 – which was after the axle’s 2003 manufacture. Discovery had revealed that the rear axle had originally been sold to the trailer manufacturer in 2003 as an “idler” axle, which has no brake assemblies and which has a plain hub without integral brake drum – see Figure 16. The Alpha idler axle, in this 5,200 pound capacity design configuration, uses a standard 25520 inboard bearing cup with matched 25580 cone assembly. The outboard bearing is a 15245 cup with matched 15123 cone assembly. It is of note that the



Figure 10

Left rear brake assembly on side opposite from separation



Figure 11

Left rear brake drum with little wear



Figure 12

Separated hub, wheel and tire assembly



Figure 13
Axle end from separated hub



Figure 14
Melted and deformed axle end



Figure 15
Deformed and abnormally worn rear brake shoe

5,200 pound Alpha axle was available with brakes and integrated hub/drum units, which also use the same 15123/15245 outboard bearing sets.

Joint Inspection, May 2009

A joint inspection was conducted with representatives from the trailer manufacturer and dealer, the rear axle manufacturer Alpha, and the rear hub/drum manufacturer Bravo. The intact left hub assembly on the rear axle was disassembled, and in doing so the expected 15123 outboard bearing cone assembly was removed. Yet this bearing cone would not install fully into the outboard bearing cup, which was still installed in the hub/drum. The outboard bearing cup was removed, and it was marked LM67010, rather than the expected 15245. The 15123 cone and LM67010 cup were assembled, and Figure 17 shows that the cone is too “big” to fit inside the cup – this is because the LM67010 cup is designed to be used with an LM67048 bearing cone, which has slightly smaller bearing surface dimensions. The 15245 and LM67010 bearing cups have the same outside diameter. In the inspection, the outboard bearing cup was then removed from the separated hub and it also was

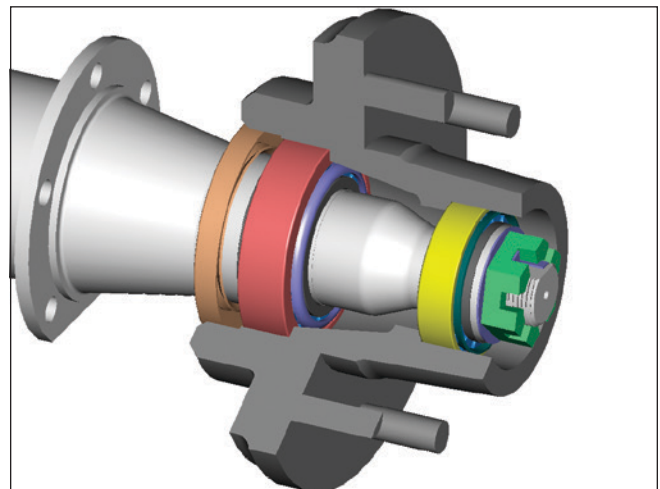

Figure 16
Idler axle cutaway

an LM67010. The partial remains of the separated hub's outboard bearing cone inner race were measured (see Figure 18), and the dimensions matched that of a 15123 bearing cone inner race. As such, it was apparent that 15123 bearing cones had been used with LM67010 cups on the rear axle.

Analysis

As mentioned, Alpha 5,200 pound axles use the 15123 outboard bearing cone with matching 15245 cup. The Bravo hub/drums used on the rear axle were also intended for use Bravo's own 5,200 pound axles – but Bravo's 5,200 pound axles use smaller, lighter duty LM67010 outboard bearing cups with matching LM67048 bearing cones. Bravo also sells 6,000 pound capacity axles, which use the 15123/15245 cone/cup – and the hub/drum casting for Bravo 6,000 pound axles is identical to the hub/drum casting for their 5,200 pound axles except for a minor machining difference: the bore depth for the outboard bearing cups.

Discovery documents revealed that the rear axle's Bravo hub/drum units were actually manufactured during the same week in 1995, twelve years before the trailer manufacture. Given the mismatch of parts on the rear axle – 2003 idler axle, 1995 hub/drums, 2006 brake assemblies – it was apparent that this mismatch was a likely contributor to the installation of 15123 bearing cones in the undersize LM67010 bearing cups.

It should be evident that a 15123 cone cannot be expected to function properly in a LM67010 cup. Referring to Figure 17, only about half of the bearing roller width actually contacts the cup, which will lead to uneven load distribution, high localized compressive stresses, and cocking of the rollers. Additionally, the cone angles are different



Figure 17
Mismatched bearing cup and cone



Figure 18
Measuring remains of outboard 15123 bearing inner race

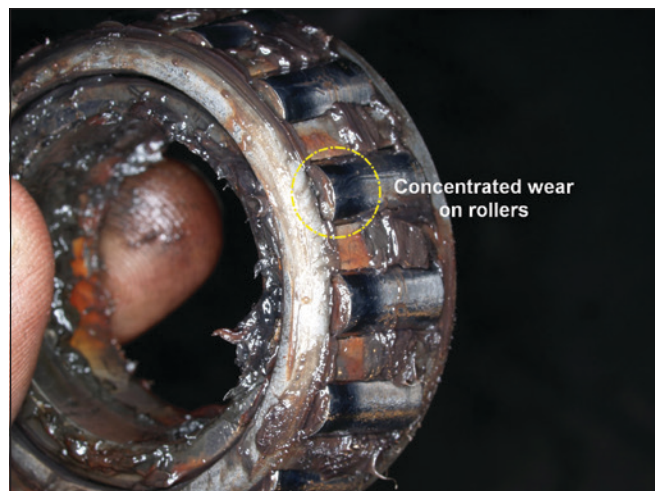

Figure 19
Left rear outboard 15123 bearing damage due to outer race mismatch



Figure 20

Assembled Delta axle hub showing ~1/8" of threads protruding from nut



Figure 21

Assembled mismatched hub (left rear) showing nut overlapping axle stub end

for the two designs. As an aside, subsequent closer inspection of the surviving left rear 15123 cone revealed compressive damage to the small-end edges of the bearing roller contact surfaces – failure of this bearing was impending. See Figure 19. It is a tribute to modern bearing design and manufacturing that these bearings lasted as long as they did. It is of note that any of the Alpha, Bravo, or Delta hub/drums, properly installed with the correct bearings, will result in approximately 1/8" of axle threads protruding from the axle nut (see Figure 20). If the subject mismatch is created, however, the inability of the 15123 bearing cone to insert fully into the smaller LM67010 cup will result in about 1/4" fewer axle threads engaged in the axle nut – the nut will “overlap” the axle end (see Figure 21). This may or may not be noticeable, depending upon the presence of grease and depending upon the expectations and skills of the observer.

The next step was to determine which party likely installed the mismatched 15123 cones in the LM67010-equipped hub/drums. A related possible scenario was that the 1995 Bravo hub/drum units had been installed after manufacture by a person unaware (or unconcerned) that the Alpha and Bravo 5,200 pound hub/drums used incompatible outboard bearings. The likely contestants for these two scenarios were the trailer owner, dealer, or manufacturer.

- The trailer owner reported that he had never replaced trailer brakes in his life. He reported owning no other trailers of comparable size. In order to replace theoretically “correct” hub/drums with the subject ones, he would have had to obtain essentially unused 1995 hub/drum units of the correct size, in 2007. And there was no reason evident why he would have replaced the “correct” parts – there were no signs of pre-incident impact damage to the axle, no signs of extreme brake wear that would justify drum replacement, no signs of pre-incident impact damage to the axle, and no signs that this rear axle would have experienced more severe road-use impacts than the apparently undamaged front axle. As such, it was deemed less likely that the owner installed the incompatible hub/drums.

- The trailer dealer did have the capability to install the incompatible hub/drums, though they had no record of doing so. During pickup from the manufacturer, the dealer had stacked multiple trailers for transport, and to facilitate this stacking the front axle's wheels would have been removed. But this leaves the rear wheels in place on the subject rear axle, which protects the drums from impact damage. The dealer's receiving process involved an overall inspection, installing the front wheels, torquing the lugnuts, and setting the tire pressures – hubcaps were not removed nor bearings checked. If there was an issue with the rear hub/drums upon receiving inspection, a warranty claim to the manufacturer would be expected. It was deemed less likely that the dealer installed the incompatible hub/drums.
- The trailer manufacturer had the capability to install the incompatible hub/drums, though they had no record of doing so. However, the following issues were revealed:
 - The manufacturer had an informal inventory control system. They took inventory weekly by looking in storage bins to see if they were running low on parts. They denied ever having purchased Bravo 12"x2" hub/drums; they typically bought Alpha and Delta brand. They purchased these hub/drum units from various wholesale vendors and had no process for quality control inspection of incoming parts – or even verification that they had received what they ordered. As an aside, the trailer manufacturer made several thousand new trailers per year in their factory, and also occasionally performed repairs for customers. They had a storage area for “scrap” parts that they would occasionally reuse for repairs.
 - The trailer manufacturer had purchased the Alpha idler axle in 2003 as a “spare” to be used for either braked or idler applications – single-axle trailers occasionally have no brakes. Conversion of an idler axle to a braked axle is a “simple” matter of bolting on the brake assembly and swapping the idler hub for the integral hub/drum – assuming all the components are compatible. The axle manufacturers in this case each stated that they recommend idler conversions only be performed using their own respective components.
 - The production technician that converted the idler axle to a braked axle and installed it (on the trailer) revealed several issues in his deposition.
 - He believed that all 12"x2" hub/drum units were functionally identical, and he was unaware of any segregation between stocked hub/drum units from different manufacturers on the stockroom shelving.
 - He claimed that he didn't pay attention to bearing cups because they were typically already installed in the hubs, and because he didn't know how to remove them. This was reinforced by other testimony that when replacing worn bearings for a repair customer he would only replace the cone assembly – and not also the cup. This reveals deficient technical skills; bearings are replaced as sets, cup and cone – a worn out cup should never be used with a new cone, and vice-versa. And it is a simple task to use a drift punch to remove a bearing cup from a hub. Installation of a bearing cup can be done with tooling as simple as a large socket wrench and a C-clamp, or an inexpensive arbor press; this is equipment that a manufacturer of thousands of trailers would be expected to have.

- The technician stated that he used a “thumb wrench” to tighten the axle nut and set the bearing tightness – again reflecting deficient technical skills. His “thumb wrench”, though undefined, was likely an adjustable wrench (which has thumb-wheel adjustment), yet manufacturer installation instructions specify a bearing preload setting process requiring a torque wrench.
- Based on the manufacturer’s poor inventory control, mixing of stock brands, reuse of used parts, and deficient technician skills, it was deemed more likely that the manufacturer installed the subject mismatch, versus the dealer or owner. The poor technical skills were considered as well in questioning whether the technician would have noticed that the grease-covered axle threads would not have protruded through the axle nut in the normal manner – due to the bearing mismatch.

Outcome of Case #1

The trailer manufacturer suggested that the bearing had failed due to a severe impact of the right rear tire with a road hazard severe enough to pop the tire, some miles before the hub separation. Yet the tire did not show damage consistent with significant travel while deflated.

The trailer manufacturer also suggested that the bearing had failed due to a roadway impact severe enough to bend the wheel (missing the tire) and fracture the brake drum. However, this would have meant that the fractured drum would have been in place for some time prior to the hub separation – yet the chunk missing from the drum would have resulted in catastrophic destruction of the brake shoes upon the slightest brake application – which did not occur.

The lack of an axle nut on the right rear is consistent with a process documented in Searle¹, wherein the failed superheated bearing causes thermal softening (annealing) of the axle nut threads and/or axle stub end threads. The softened threads yield and the nut comes off, and eventually the hub comes off.

Case #2 – hub separation from a 22-foot commercial gravel trailer

Case facts: A trucking company had a fleet of dozens of gravel trailers, which their drivers would use in supplying gravel for construction projects. The trailers have dual rear axles with cast spoke wheel hubs and drum brakes. The hubs use oil-bath tapered roller bearings. In January 2004, a truck tractor and a model year 2000 gravel trailer were carrying the first load of the day, and were traveling at approximately 40-45 mph approaching a traffic light on a two-lane rural highway. The left rear trailer hub separated, carrying with it the drum, two rims, and two tires. The assembly sideswiped a pickup truck traveling in the other direction. Both the axle end and the separated hub assembly were observed to be on fire, due to burning hub oil. The outboard tire blew off the hub/wheel assembly. Following the hub separation, the subject trailer was towed back to the company’s facility, the axle replaced, and the trailer used for several years prior to the author’s involvement in the case. See Figures 22 - 25.



Figure 22
Subject tractor and gravel trailer after incident



Figure 23
Left rear axle with missing hub

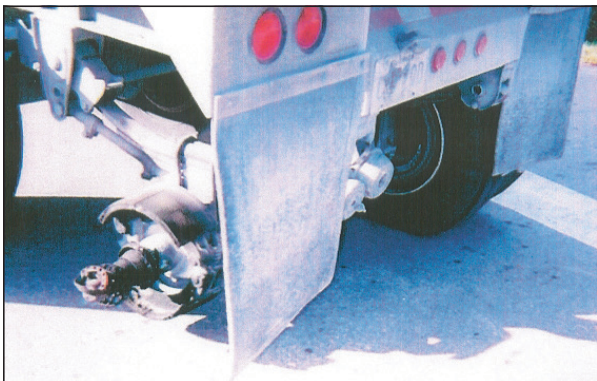

Figure 24
Separated hub, wheel, and tire assembly



Figure 25
Damaged vehicle struck by separated wheel-end

Selected discovery information

The trucking company had its own in-house servicing facility, and was asked to provide all service records, in the interest of documenting maintenance intervals and repairs. An extensive collection of print-outs from the corporate invoicing database outlined the billing for all trailer repairs. Over the course of the year preceding the incident, several repair tickets mentioned service work that could have related to wheel bearing issues. However, the invoice line items, when entered, did not mention which of the trailer's four hubs the service had been completed on. The trucking company did not have hub odometers on these trailers, and trailer mileage could not be inferred from tractor mileage. As such, trailer mileage remained untracked. Lube and oil changes were reportedly done every thirty days, though there weren't many service invoices that supported this.

A service technician from the trucking company was deposed – however, his responsibilities were limited to conducting DOT inspections, maintaining fluid levels, and airing tires. He had no specific recollection of any repairs to the trailer's wheel bearings, and could not name specific technicians that would have done this work.

The weight ticket for the load of gravel onboard at the time of the incident revealed that the trailer was approximately 5% overweight.

Analysis

The service records were requested in an effort to determine whether reasonably periodic and thorough maintenance had been performed, and whether hub bearings and seals may have failed prematurely, possibly indicating a manufacturing defect. However, the level of detail provided by the service invoicing records was insufficient to make this determination – plus the invoice data entry people were not technicians and as

such would be less concerned with the details and accuracy of the service task descriptions. The trucking company stated they had stored the original hand-written service diagnoses/work orders in a storage container that later suffered water ingress during a hurricane, destroying the records. As such, efforts were made to “read between the lines” of the service invoice records to see if there was any way to reasonably infer the history of the trailer’s servicing and repairs. It is worth noting that periodic maintenance/inspection is often done concurrently with unplanned repairs – and is often not documented.

- Service invoices dated 4/21/2003 and 9/5/2003 documented that one hub set of wheel bearings (with seal) had been replaced.
 - Standard tapered roller bearings are a refined product and may last for hundreds of thousands of miles, depending upon service conditions. The axle manufacturer recommends wheel bearing inspection whenever the lubricant is replaced. Bearings may be affected by inadequate lubrication, impact damage during hub removal/replacement, excessive adjustment freeplay or preload, and other issues discussed previously. The wheel bearing series used for this trailer is shown in Figures 26 & 27.



Figure 26

HM218248 bearing style used on subject axle

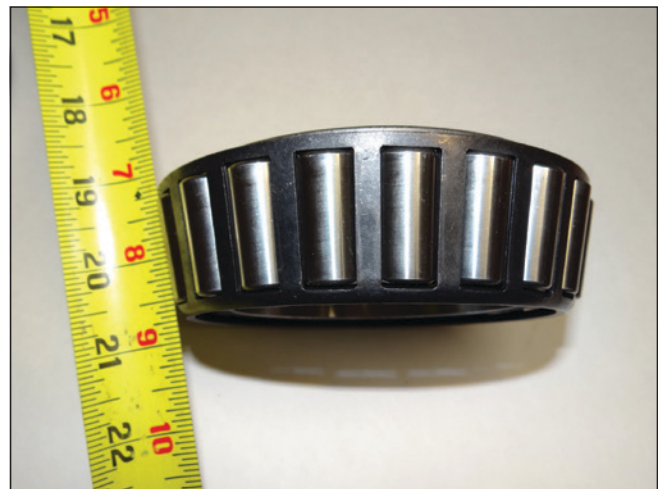

Figure 27

HM218248 bearing style used on subject axle

- A service invoice dated 6/9/2003 documented that two hubs’ oil seals had been replaced.
 - A failed oil seal could have resulted in a lubricant-starved bearing, which may have suffered life-reducing damage.
 - Oil seals may wear out, suffer damage in a hard roadway impact, experience eventual failure following careless or abusive installation, be inadvertently damaged during installation or removal of the hub, “blow out” due to overfilling of the oil reservoir, fail due to compatibility issues with the lubricant, or fail due to related causes.
 - Truck drivers typically perform a daily pre-trip inspection, and should look for hub oil leaks that denote a leaking seal and diminished lubricant volume in the hub. However, a recent seal failure may not have leaked enough for the driver to notice without an atypical level of effort. Also, this trailer had hub caps with “see through” windows that allows viewing of the hub oil

level – the axle manufacturer recommends checking oil level every 1000 miles. These hub caps provide an opportunity for the driver to verify adequate hub oil levels.

- The reason for these seal replacements were not documented on the service invoice. However, the operation requires removal of the hubs – which affords an opportunity for bearing inspection and lubricant replacement. The axle manufacturer recommends hub oil replacement every 30,000 miles for heavy duty service – and gravel hauling is a heavy duty operation.
- Service invoices dated 6/9/2003, 8/13/2003, 9/29/2003, and 12/9/2003 each documented that brake shoes had been replaced.
 - Commercial tractor/trailer brake shoe replacement can be necessitated by many things, including oil-soaked brake shoes (due to a failed oil seal), uneven brake shoe wear (due to braking mechanism issues), wear due to long use, and excessive wear & overheating of the friction surfaces due to a sticky air chamber or malfunctioning slack adjuster. Manufacturers recommend replacing both left and right shoes on an axle at the same time, even if only one side needs replacement – this helps to facilitate even side-to-side brake performance and avoids confusing the wheel sensors on ABS brakes (for newer vehicles). For the 8/13 and 9/29 services, however, only one set of shoes were replaced.
 - Typically the replacement of brake shoes on this type of hub requires removal of the hub, which again provides the opportunity to inspect bearings, inspect the oil seal, and refresh the hub oil. However, this particular trailer was fitted with an unusual type of “cartridge” brake shoe that can be removed and replaced without removing the hub and exposing the bearings and seal. See Figure 28.

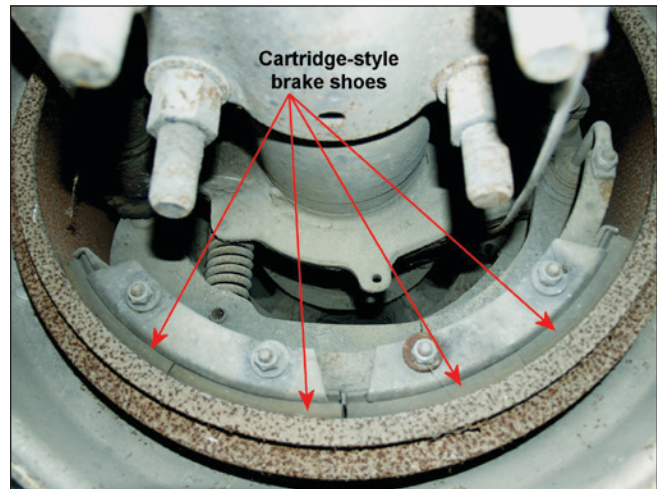

Figure 28

Cartridge-style brake shoes on subject trailer axle.

As can be observed, there clearly were service & repair operations conducted on the hubs, brakes, seals, and bearings – all components that can contribute to a hub separation. That these components were serviced could suggest that proper servicing was being performed but perhaps not documented thoroughly. The key difficulty was in establishing which hub and axle had received each different repair.

Further analysis of the photographs, particularly Figure 29, resulted in several observations, as follows:

- The axle stub is missing the outer axle nut and tabbed lockwasher, though the perforated locking ring is present. The outer axle nut could have deformed sufficiently (with heating) to loosen and fall off, or the axle stub threads could have been damaged.

- The outboard bearing cage and rollers are gone; the inboard bearing cage is present. Due to the difference in bearing diameters (outboard being smaller), the outboard bearing in an oil-filled hub will fail sooner in a low-lubricant situation – see Figure 30.
- The brake shoes appear to have staining and localized bands of wear consistent with a hub oil leak. The staining could also be merely products of combustion caused by the hub oil fire – the evidence was not directly inspected by the author.

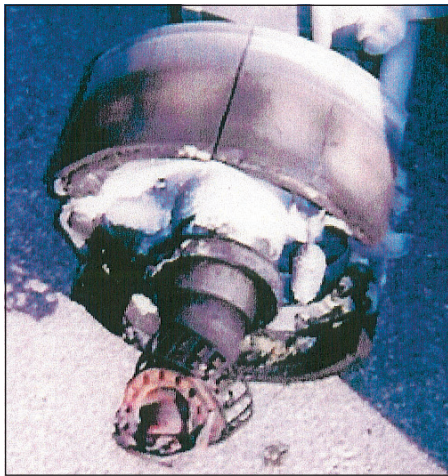

Figure 29
Subject axle end post-incident

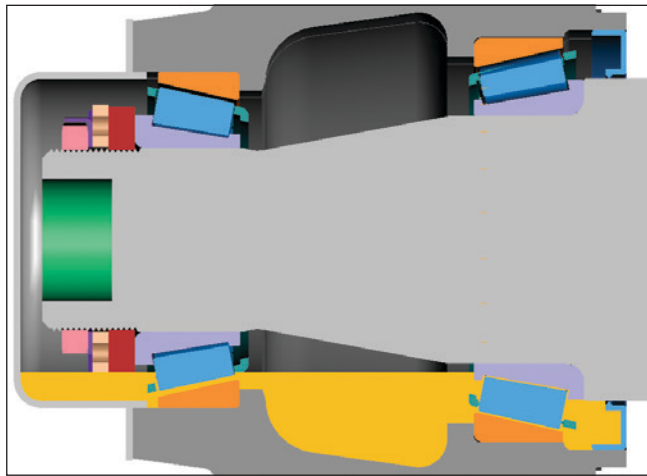

Figure 30
Oil-filled hub showing smaller outboard bearing will starve first in a low-oil condition.

Outcome of Case #2

As the case approached the discovery deadline, the trucking company eventually revealed the original service diagnoses and work orders. These documents revealed that the left rear hub/drum/rims/tires assembly had separated on 4/23/2003, had been repaired, and had separated again on 9/5/2003. The axle stub end threads had been damaged during the 9/5/2003 hub separation, so they were welded up and rethreaded. The left rear hub separated again (for the third time in nine months) in late January 2004, leading to the subject litigation.

Conclusions

Vehicle hub systems have many interrelated components which, if compromised, can lead to catastrophic hub separation incidents. Design, installation, usage, and maintenance issues can all affect the integrity of the hub/vehicle joint. In the first case study, the specific failure mode was apparent, yet determining the likely responsible party took some effort. In the second case study, the specific failure mode could only be assumed initially, and evaluating the trucking company's efforts to proactively mitigate potential failure opportunities took some effort – until it was revealed that their efforts were substandard.

Reference

1. Searle JA. The detachment of wheels from commercial vehicles. SAE Technical Paper 861974, Society of Automotive Engineers, Warrenton PA, 1986.