

Journal of the
National

Academy OF

Forensic

Engineers[®]



<http://www.nafe.org>

ISSN: 2379-3252

Forensic Engineering Investigation of Incidents Involving Corded Window Coverings

by Richard M. Ziernicki, Ph.D., P.E. (NAFE 308F)

Ben T. Railsback, P.E. (NAFE 713S)

Abstract

It has been recognized for many years that young children have been involved in incidents, including strangulation, with the cords associated with window covering products such as window blinds or shades.^{1,2} The Consumer Product Safety Commission (CPSC) has identified window coverings with cords as one of the top five hidden hazards in the home. According to CPSC a child dies about once a month and another child suffers a near strangulation.³ The CPSC currently recommends the use of cordless products wherever children live or visit.

This paper will identify the hazards, or design features which create loops, associated with corded window covering products based on incident reports and design analysis. The paper will further identify the risk, or the probability and severity, associated with the hazard modes. Additionally the paper will address historical and current engineering design efforts to reduce the injury potential for corded window coverings.

Keywords

Window coverings, Blinds, Mini-Blinds, Venetian, Roman Shades

Case Study

On January 17, 2008, a male child, approximately 3 ½ years old, was playing in his bedroom while his older teen-aged sister was babysitting. The older sister stated that she put the male child in his bedroom, located on the main level of the house, at around 2 p.m. on the day of the accident. The sister then went downstairs to the basement level while the male child was upstairs watching television in his bedroom.

A window located in the child's bedroom had a horizontal window covering, or blind, with 1-inch aluminum slats, manufactured by a prominent window covering manufacturer. The window covering was mounted external to the frame surrounding the window. The blind covered the window, which was approximately 69 inches wide by 58 inches tall. A futon, formed into a sofa, was positioned next to the window. The top edge of the futon sofa was positioned at the bottom edge of the window. See Figure 1. According to the child's mother, the window covering was present when the house was purchased. The child's mother did not know who installed the window covering. The house was purchased in June, 2007.

The older sister stated that she had gone downstairs to the basement level of the house to watch television while the child was upstairs in his bedroom. The sister stated that she frequently called up to the child to check on him while she was downstairs. The sister went upstairs to check on the child and found him with the window covering pull cord wrapped around his neck. The sister was unsure how the child gained access to the pull cords. The mother of the child stated that the window covering cords were usually kept high out of reach of the child, placed on top of the top rail of the window covering. The ends of the window covering pull cords were found knotted together, and the sister had to cut two of the cords apart to free the child's neck from a noose. After an attempted resuscitation, the child succumbed to the injuries from the window covering cords. According to the Coroner's report, the window covering cord was wrapped around the child's neck, causing asphyxia due to hanging.



Figure 1
Photograph of the Incident Scene.
(Photo by Police Department)

Product Identification: The subject window covering was manufactured in 1998. The window covering consists of an aluminum header rail, followed by one inch wide aluminum slats connected together by webbed cords formed into ladders, attached to an aluminum bottom rail. The tilt control of the aluminum slats is accomplished by a plastic wand located on the side of the window covering that controls the ladders and turns the pitch of the slats. Lift control of the window covering is controlled by three cords. The three cords attach to the bottom rail of the blind, travel through the slats, are routed through the header rail, and are collected together on the right side of the window covering. Raising and lowering of the aluminum slats and bottom rail is accomplished by pulling on the lift cords on the right side of the blind. The pull cords are each terminated with a separate plastic tassel.

A warning label is located on the bottom rail. See Figure 2. The warning label consists of a graphic of a child reaching for the pull cords of the window covering, a yellow label stating warning, followed by the phrase:

“Young children can become entangled and strangle in cord or bead loops. Use safety devices to reduce access or eliminate loops.”

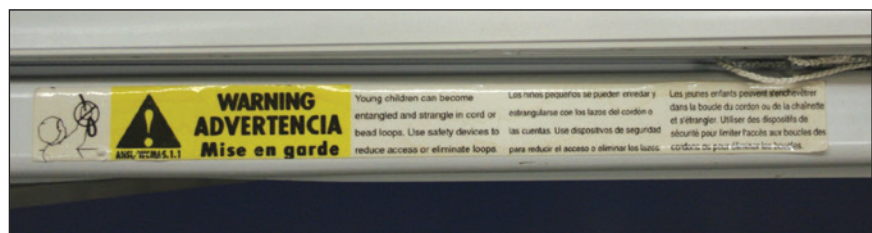

Figure 2
Warning label located on the bottom of the subject window covering.
(Photo by Police Department)

According to a Consumer Product Safety Commission (CPSC) report regarding the incident, a window covering similar to the one present at the accident scene was obtained from the home. The CPSC report indicated that the exemplar window blind was manufactured by a prominent window covering manufacturer. The window covering measured approximately 71 inches wide with pull cords that were approximately 96 inches long when fully extended. There were three individual pull cords, each with a separate tassel on each end. The three pull cords were knotted together a few inches from the end, forming a loop. A similar warning label was affixed to the bottom rail of the exemplar blind.

The authors were retained by plaintiff's counsel to provide forensic engineering services in the investigation of the incident. Following analysis, engineering report, and deposition testimony by this office settled favorably for the plaintiff. Some of the engineering analysis, techniques, and findings are reported in this paper.

Hazard Analysis

Window covering products such as mini-blinds and roman shades are typically raised and lowered by the use of cords. Other window covering products such as cellular shades and vertical blinds employ a looped cord to open and close the window covering vertically or horizontally. The use of cords within these products has created a hazard to young children. Children have been known to suffer asphyxiation injuries as a result of cord loops associated with window coverings.

Review of CPSC incident investigation reports and window covering designs has shown that hazardous loops generally form in two areas; outer cords and inner cords. Outer cords, also referred to as operating or pull cords, can be defined as the cords that are used to actuate or raise and lower window coverings. For example, most mini-blinds have an outer pull cord used to raise and lower the blind. Similarly, vertical blinds can be equipped with a looped cord or chain to draw the blind laterally. Inner cords, or internal lift cords, are the cords typically within the window covering that interact with the window covering to transfer force and produce movement. Mini-blind inner cords travel from the header rail down through the slats to the base rail of the blind, while roman shades have cords that are attached to the window side of the window covering.

Outer cord loops are either inherent in the design of the window coverings or form during use of the product. Older window covering products employed the use of a continuous, looped cord to raise and lower or open the window covering. Some older horizontal blinds had multiple pull cords joined together. The junction of multiple cords or the use of a continuous cord will inherently create a loop. Newer horizontal blinds have



Figure 3
Continuous Loop
In an Outer Cord



Figure 4
Tangled Outer Lift Cord

separated the cords and use individual tassels; however, the individual cords may become tangled or even knotted during use, forming a hazardous loop, or the cord can be wrapped around a child's neck to form a loop. Figures 3 and 4 illustrate hazardous loops associated with outer cords.⁴

Inner cord hazards are typically less obvious than outer cord hazards in part because the cords are not normally used by the operator. The inner lift cords on horizontal blinds can be pulled out from between the slats of a blind to form a free standing loop. The loop forms when slack from the outer lift cord is pulled through the head rail. The inner cord may also be pulled upward, lifting the base rail. Slack in the inner lift cord is created by collapsing the slats of the blind together, forming a hazardous loop. Inner

cord loops associated with horizontal blinds are illustrated in Figures 5 and 6. Inner cord injuries have also occurred on other products such as roman shades when a child's head becomes caught in a lift cord loop behind the covering. The loop could be partially composed of the material of the window covering itself in combination with the lift cord. Figure 7 illustrates such a hazard.⁵



Figure 5
Inner Cord Loop from Slack



Figure 6
Inner Cord Loop from Raised Base Rail



Figure 7
Roman Shade Inner Cord

Risk Assessment

Risk is a combination of the expected frequency of an event and severity or consequences of an event. Most corded window covering incidents involve asphyxiation injuries that either result in fatal injuries or significant brain injury due to oxygen deprivation. Therefore, in a risk assessment context, corded window covering incidents are typically severe incidents resulting in serious injury or death.

Analysis of the incident reports collected by the CPSC shows the frequency and severity of incidents associated with corded window coverings. The data set reviewed for this research consisted of 449 incident reports spanning three decades, from 1981 to 2010. The data set consists of 377 fatal incidents and 72 injury incidents. It is likely that injury incidents and near miss incidents are underreported in the data set when no significant, lasting injury occurs. A *Journal of the American Medical Association*

study further found that CPSC files document only 51% of the total window-cord strangulations in the United States between 1981 through 1995.⁶ Therefore there is underreporting in the data set from a risk assessment perspective.

The data set from the CPSC indicates the frequency of incidents over the 30 year time span in which data has been collected. On average, there are approximately 15 incidences per year (approximately 12 fatalities) involving corded window covering products. Annexes A and B depict the annual incidence data and the cumulative incidence data within the data set.

The incidence reports contain varying levels of information. When the information was available, the age, gender, style of window covering, design feature associated with the injury, and method of access to the window covering was collected from the report.

The data set shows that the average age of the victim was about 2 years old (dataset is based on yearly bins). However, there are no reported incidents involving typical adults, which indicates that the vulnerable population set is primarily the very young and the mentally diminished elderly. Annex C depicts the age distribution of individuals involved.

There is evidence that male children are more likely to be involved in a window cord covering incident. Males composed 60% of the data set while females represented 40%.

In approximately 35% of the incidences, the data set indicates the method by which access to the window covering was gained. The majority of the reports do not indicate the method by which access was gained. Within that 35%, access to the window covering was gained through beds, cribs, furniture, window sills, or toys. Movement of furniture away from windows may reduce injuries; however, the significant number of incidences where access did not involve furniture indicates that removal of furniture alone will not eliminate the danger associated with window coverings. Annex D depicts methods of access including unreported or unknown access. Annex E depicts method of access for known incidents only.

The style or design of window covering has been identified in approximately 80% of the incident reports. The incident frequency for a particular style of window covering is a function of both the number of such window coverings in use and the hazards associated with such window coverings. The data set shows that horizontal blinds are the style of window covering that is most often involved in window cord incidents. Horizontal blinds may have hazardous outer lift cords in addition to hazards associated with the inner lift cords. Vertical blinds, which typically have a continuous cord loop to draw the blind, are the second most represented style of window covering in the data set. Annex F depicts the styles of window coverings involved in the incidents.

When possible the method in which the injury incident occurred had been identified to determine which design features of window coverings are the most dangerous. Continuous looped cords have been cited in 236 incidences as the design feature implicated in the injury. Continuous looped cords include looped cords, looped chains, cord joiners, and tasseled pull cords. The second method of injury that is most often implicated in incidents is an inner cord. The third method of injury most implicated in incidents is the wrap-around of the operating cord of the blind. These categories are typically associated with an injury created by the outer pull cord. Annex G depicts the injury incident data grouped by method of injury incident.

Development of a Safety Standard

In 1981 the CPSC produced a special report titled “Accidental Strangulations (Ligature) of Children Less Than 5 Years of Age.”⁷ The study examined 300 incidents of accidental strangulation, most resulting in death, over the period of 1973 to 1980. One of the key findings of the study was that drapery and blind cords were the second leading cause of strangulation of children under the age of 5. The study represents a significant milestone (outside of the window covering industry) in recognition of the hazard of window covering cords to young children.

In 1985 the CPSC and the American Window Covering Manufacturers Association (AWCMA) worked together on an “Alert” to notify consumers of the hazards posed by window covering cords. The alert provided advice to consumers on how to reduce the risk associated with the hazards of corded window covering products. The alert was reissued in 1989 in response to the realization that deaths were still occurring.⁸ At the time that the CPSC was investigating strangulation incidents in the early 1980’s there were no national consensus standards regarding the safety of corded window covering products.

In 1996, the American National Institute of Standards issued “ANSI/WCMA A100.1-1996 American National Standard for Safety of Corded Window Covering Products” sponsored by the Window Covering Manufacturer’s Association (WCMA, a successor of the AWCMA). The stated intent of the voluntary consensus standard is to encourage the development of devices that will further improve the safety of products manufactured by industry members. The standard establishes minimum safety requirements for corded window covering products. Performance requirements within the standard are intended to decrease the danger associated with window coverings. The product requirements relative to strangulation hazards include the following:

- The elimination of cord and bead loops through the use of passive devices, such as cord tassels that separate the cords.
- The elimination of exposed cords or bead loops through the use of a passive device such as a cord retraction device.
- Limiting the exposure to cord or bead loops through the use of passive tension devices mounted to walls or floors.

- Products requiring the use of cord stops (also known as cord connectors) shall minimize the exposed loop to less than three inches from the top of the head rail when the product is in the lowered position.
- Requiring that products shall contain materials that house the cord and shield it from exposure.

The standard also provides guidance on warnings and testing procedures to meet performance requirements within the standard. The standard has been updated several times since 1996. Major revisions included updates in 2002 to prevent the formation of inner cord loops through the use of cord stops, and an update in 2010 to address roman shade inner cord hazards. There is currently a 2014 version available, which is a revision of the 2012 edition. The 2014 version separates product design requirements into inner and outer (or operating) cord requirements. The standard allows multiple paths for compliance, which from a practical standpoint means that some products that comply with the standard are safer than others.

The operating cord requirements allow a window covering to comply if it has no operating cords which are accessible, has separate operating cords, has a cord release device in the loop or head rail, has a permanently attached cord retraction device, a cord shear device, a cord tension device, or a cord loop or bead chain restraining device. There is also a requirement to limit the exposed loop created by cord connectors to less than 3 inches from the bottom of the cord lock. Products with a cord connector also require an additional warning.

The standard also creates multiple compliance paths for inner cord hazards. The window covering will comply with inner cord requirements if it has no inner cords, has no accessible inner cords, has accessible inner cords that meet certain test requirements, has an inner cord shroud that meet certain test requirements. There is also a requirement that inner cord stop devices or cord connectors are positioned 3 inches or less from the head rail when the bottom rail is in a fully lowered position. Roll up blinds have separate test requirements as well.

Since the design requirements for operating (outer) cords and inner cords allow multiple compliance paths that still allow the use of cords, and do not mandate “cordless” designs there is still a hazard (potential for injury), a risk (probability of injury), and therefore danger associated with many products that comply with the standard.

Safety Engineering

Although a safety standard for window coverings did not exist until 1996, safe product design concepts existed well before 1996. Most safety engineering texts recognize a hierarchy or order of precedence in relation to controlling and/or eliminating hazards. The International Organization for Standardization (ISO) summarizes the recommended strategy for selecting safety measures in ISO 12100-1-1992.⁹

The standard states that as a part of the strategy for selecting safety measures, the designer shall, in all circumstances, in the following order:

- Specify the limits of the machine
- Identify the hazards and assess the risks
- Remove the hazards or limit the risks as much as possible
- Design guards and/or safety devices (safeguards) against any remaining risks
- Inform and warn the user about any residual risks
- Consider any additional safety precautions

The standard recognizes that the strategy for selecting safety measures is an iterative process where designers may need to reevaluate products several times.

The process has been summarized more succinctly as “design, guard, warn.” When hazards are recognized with products the designer should first attempt to design the hazards out, then guard against remaining hazards, and as a final precaution warn against any residual hazards. The process is graphically summarized in Figure 8.

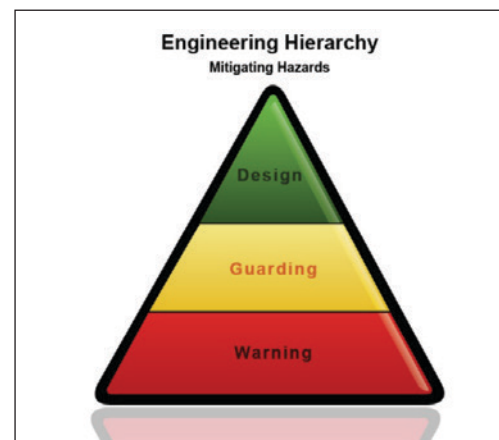

Figure 8
Engineering Hierarchy of Hazard Mitigation

Alternative Designs

This study has identified several alternative designs that could protect against strangulation hazards of window covering cords. Alternative designs have been identified through the literature review of past products, a benchmark study of currently available products, a review of patent documents, and the development of prototypes by the authors. The following sections provides a brief description of the technology generally following a timeline of development

Cord Cleats and Short Cords: Cord cleats are a technology that has been used in the window covering industry to provide the user of the window covering a location to wrap the pull cords which is above and out of reach of young children. Short lift cords are designed to reduce the free length of window covering pull cords to a minimum in an attempt to reduce a young child’s access to the pull cords. The 1985 CPSC alert issued in conjunction with the WCMA recommended the use of short cords and cleats. Short outer pull cords offer two advantages. The first advantage is that when the window covering is in the lowered position, the short cord is raised out of reach of children. The second less obvious advantage is that short cords position the end of the cord, or tassels, near the header rail. When a child pulls on the inner cord of a window covering, the tassels on the short cord will act as a stop and prevent the child from drawing the inner cord out of the window covering thereby preventing the formation of a hazardous loop. Therefore, short cords reduce the hazard associated with both outer lift cords and inner lift cords.

While cord cleats can provide a position for the cord out of children’s reach when the window covering is drawn (in essence guarding by location), the operator of the window covering must actively use the cord cleat after opening the window covering. Incident reports show that cleats are not always installed or used properly resulting in severe injuries or death. Safety devices that require active user intervention are less desirable and renders products employing short cords and cleats more dangerous than products that eliminate the hazard. Therefore cleats and short cords are not a solution to the danger posed by cords.

Cord Collectors: In the past, operating outer lift cords on window coverings have terminated in continuous loops or single tassels that effectively join the cords together in a hazardous loop. A 1990 patent, filed by Langhart, et al.¹⁰ described a window covering cord connector that collected the individual cords together into one tassel. However, Langhart’s tassel is designed to break apart and release the cords should a child’s neck apply a force to the cords (See Figure 9). The tassel was designed to release the individual strands of cords when the cords were subjected to a pulling force between the tassel, such as when wrapped around a young child’s neck. In the following statement taken from his patent, Langhart identifies a specific safety mechanism he developed in regards to the design:

“A safety device including first and second members is attached to the pull cords for window coverings to prevent children from strangling when the children play with the pull cords.”

Patents developed by Te-Tsun Wu¹¹ and Weppner¹², describe designs of similar functionality to the Langhart design (See Figures 10 and 11). Wu states in his patent:

“[The design] can prevent a child from strangling when the child’s neck gets caught between the cords.”

Weppner states similar awareness of safety concerns of young children in his patent:

“The window coverings industry is generally moving away from [looped] cords due to the hazards they present, particularly for small children who may inadvertently become entangled in the loop.”

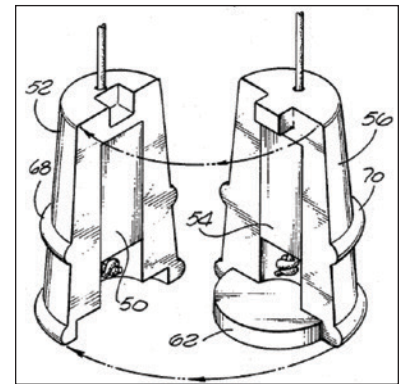

Figure 9

Langhart Patent #4909298

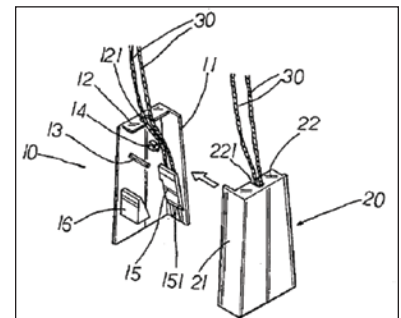

Figure 10

Wu Patent #5473797

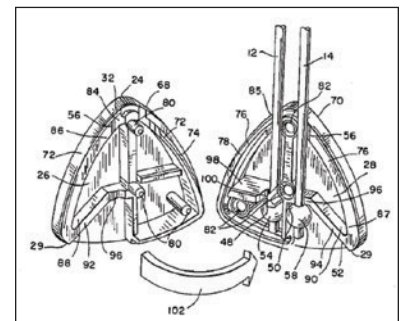

Figure 11

Weppner Patent #5504977

Technology such as the safety releasing tassels developed by Langhart, Te-Tsun Wu, and Weppner would provide the operator with a mechanism to allow the window covering pull cords to be collected

and operated uniformly, and additionally, would reduce the likelihood of young children being strangled by loops created at the ends of the pull cords.

A 1995 patent by Biba¹³ described a cord connector that connected two or more cords together into a retaining device. The retaining device was designed to release in response to a force, such as a child's head, pulling the cords apart. The patent states:

“Problems have been encountered when infants or children play with the operating cords and tassels and introduce some limb or their head and neck between some of the operating cords.”

The patent further stated the following:

“In order to maintain the bottom rail horizontal when raising and lowering the window covering, it is necessary to equalize movement of the operating cord portions of the lift cords. In some installations, multiple operating cords are tied together in a knot to equalize movement of the operating cord with a cord pull provided to cover the knot.”

The Biba cord connector also improved window covering performance in two ways. The cord connector would equalize movement of the blind pull cords while it eliminated multiple pull cords below the cord joiner (cord connector). May applied to patent a similar technology in 1997.¹⁴ May stated in the patent that another advantage of the technology of a break away cord joiner is that the joiner would act as a cord stop or “slack preventer” which would prevent loops from forming due to slack in the inner cords.

While break away tassels potentially eliminate an easily accessible loop, there are significant drawbacks. The tassels must be designed for easy reassembly to prevent tangling when they are reassembled after a break away. Several designs evaluated have not performed consistently or reliably. Finally, break away tassels do not eliminate a wrap-around hazard posed by a long cord. Therefore break away tassels or cord connectors (joiners or stops) are not a solution to the danger posed by cords.

Cord Retraction Device: McCluskey developed a patent in 1979 that incorporated a cord control apparatus onto the free end of window covering lift cords.¹⁵ See Figure 12.

The control apparatus was designed to collect the excess length of pull cords from the side of the window blind into an enclosed spool that would hang near the top rail of the window blind. The primary function of this control apparatus was to minimize the excess length of the pull cords. By reducing the uncontrolled length of the pull cords, the design limits access to the pull cords and thereby minimizes the potential for strangulation.

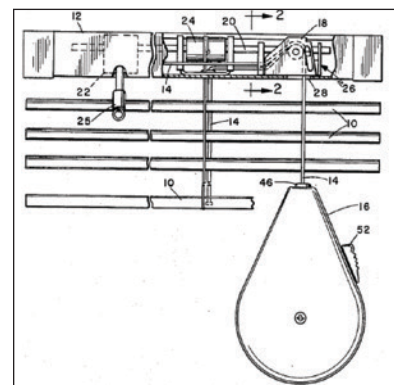

Figure 12
McCluskey Patent #4271893

A device such as the one patented by McCluskey minimizes the exposed length of the cord, and may act as a stop to prevent inner cords from being pulled out. However, the retraction must be reliable, and requires active user intervention. Therefore, the cord retraction device as patented does not eliminate the hazard and is not a solution to the danger posed by cords.

Cord Shrouds: Biba has also developed a patent that consists of a cord shroud that encloses the pull cords within a tube.¹⁶ See Figure 13. Biba identified the safety hazard associated with window covering pull cords and stated that there were aesthetic advantages to enclosing the cords:

“The dangling ends of the lift cords are not only aesthetically undesirable but also presents a potential safety hazard to children that can reach and play with such cords.”

The design describes operation of the window covering pull cords by using a separate larger diameter sleeve that fits around the cord shroud. The sleeve is attached to the pull cords of the window covering, and the operator controls the level of the window covering by moving the sleeve up and down the cord shroud. Biba further developed the design with another similar patent that was applied for within the same time period.¹⁷ (See Figure 14). Language from the patent describes the safety issue commonly encountered in using window covering lift cords. The patent states:

“Problems have been encountered when infants or children play with the operating cords and tassels and introduce some limb or their head and neck between some of the operating cords.”

Another patent, filed by Tuzmen et al. in 1996¹⁸, incorporates a series of telescoping tubes that encloses the pull cords of a window covering (See Figure 15).

The tubes are designed to nest concentrically within each other and provide a physical barrier between the pull cords and the operator, reducing the risk of strangulation imposed to small children. The patent states the following:

“Relates to pull cords for window coverings, more particularly, to a safety device for housing the pull cords to protect children from injury when they come in contact with such cords.”

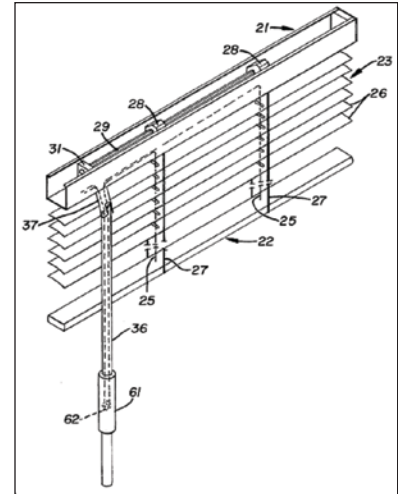

Figure 13

Biba Patent #5465775

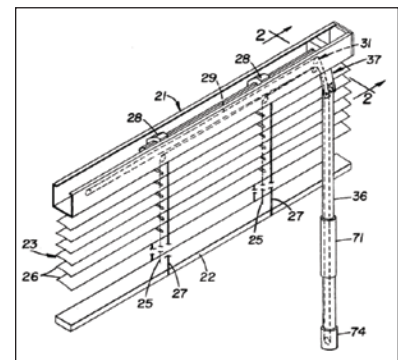

Figure 14

Biba Patent #5562140

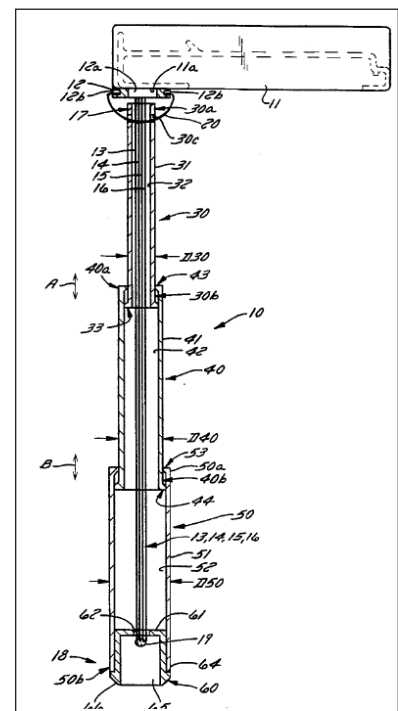

Figure 15

Tuzmen Patent #5513687

Jacobson recognized the safety hazard associated with corded window coverings and applied for patents in 1995¹⁹ and in 1997.²⁰ Jacobson developed a unique method of controlling blinds using a wand with a spiral twist. The wand is equipped with drive nuts to raise and lower the blind. The drive nut is moved up or down the spiral wand, essentially a power screw, creating shaft power which can be used to raise or lower the blind. Jacobson stated the following in his patent:

“There is a need for a cordless system for raising and lowering shades and blinds, and for rotating vertical louvers and horizontal slats, as well as traversing vertical blinds, open or closed, without the use of an operating cord.”

Jacobson’s spiral wand for raising and lowering blinds is depicted in Figure 16.

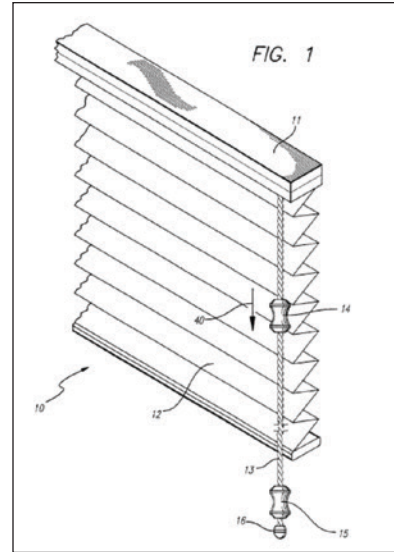

Figure 16
Jacobson Patent #5476132

Cordless Window Coverings: The CPSC currently recommends the use of cordless window covering products in all homes where children live or visit.²¹ Patents regarding cordless window coverings have been filed that incorporate various spring devices to counterbalance the window covering and eliminate the use of operating or pull cords altogether. A patent filed in 1945 by Cohn describes the use of such springs to provide a lifting force to the horizontal slats of a window covering.²² Positioning of the slats is accomplished by moving the bottom rail of the window covering (See Figure 17). Kuhar developed a similar patent in 1996 that incorporated the use of a spring motor into the top rail of the window covering.²³ The spring motor compensated for the weight of the window covering such that lifting and lowering of the bottom rail positioned the window covering at the desired location. See Figure 18.

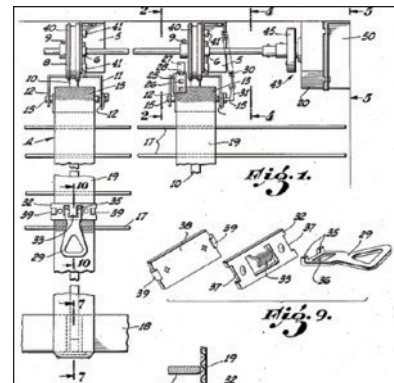

Figure 17
Cohn Patent #2390826

An analogous design to the cordless window covering that most engineers will be familiar with is a residential garage door. Helical coil springs store spring energy to help raise the garage door, converting spring energy into potential energy. As the door is lowered the potential energy is converted back to spring energy until the door reaches the lowest potential energy state.

Typical window covering outer lift cords are not used in the design developed by Kuhar, therefore, the hazard posed to young children by the outer lift cord is eliminated. Cordless window coverings of the design outlined in Kuhar’s patent are currently commercially available to consumers.

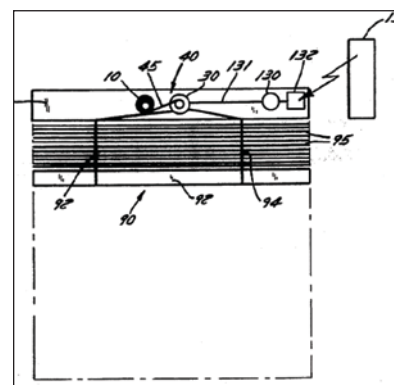

Figure 18
Kuhar Patent #5531257

Summary/Conclusion

A significant hazard exists for young children from loops formed from the cords of window coverings. This paper has identified several different ways, or failure modes, in which these hazardous loops are formed. This paper has also identified risk factors such as occurrence rates, the magnitude of the problem, age and gender of victims, methods of access to the window covering, and style of window coverings involved. Finally, alternative designs to improve the safety of window coverings have been identified.

Knowledge of the serious injuries associated with window coverings and existence of alternative designs to improve the safety of window covering products should reduce the rate of incidents in the future provided that manufacturers of window coverings implement safer designs.

References

1. ANSI/WCMA A100.1-1996 American National Standard for Safety of Corded Window Covering Products, p. 4, 11/27/1996
2. Many doors are also covered by a corded covering product. This paper generally refers to window coverings; however, door covering products have also been analyzed.
3. CPSC Safety Alert, "Are Your Window Coverings Safe?" 10/30/2009
4. CPSC Safety Alert, "Are Your Window Coverings Safe?" 10/30/2009
5. CPSC Safety Alert, "Are Your Window Coverings Safe?" 10/30/2009
6. "Pediatric Window-Cord Strangulations in the United States, 1981-1995," Renae Rauchschalbe, N. Clay Mann, *JAMA*. 1997;277(21):1696-1698.
7. Rutherford, George. "Special Report, Accidental Strangulations of Children Less Than 5 Years of Age." United States Government Memorandum, U.S. Consumer Product Safety Commission, 7 May 1981.
8. Rutherford, George. "Emerging Hazards Project Recommendation-Window Cords." United States Government Memorandum, U.S. Consumer Product Safety Commission, 8 Sept. 1992.
9. "ISO 12100-1:1992 Safety of Machinery - Basic Concepts, General Principles for Design." *International Organization for Standardization* 1.1 (1992): p. 16.
10. Langhart, Richard M., and Karen F. Langhart. Window Covering Cord Pull Safety Device. Patent 4909298. 20 Mar. 1990. Print.
11. Wu, Te Tsun. Safety Device for Fixing Cords of Venetian Blind. Patent 5473797. 12 Dec. 1995. Print.
12. Weppner, Mark. Device for Releasably Holding Cords. Newell Operating Company, assignee. Patent 5504977. 9 Apr. 1996. Print.
13. Biba, Scott I. Releasable Operating Cord Connector for Window Covering. Springs Window Fashions Division, assignee. Patent 5562140. 8 Aug. 1996. Print.
14. May, Vincent Lee. Safety Device and System for Window Covering Pull Cords. Patent 5906233. 25 May 1999. Print.
15. McClusky, William A. Window Blind Control Apparatus. Patent 4271893. 9 June 1981. Print.
16. Biba, Scott. Venetian Blind with Wand Operator. Springs Window Fashions Division, assignee. Patent 5465775. 14 Nov. 1995. Print.

17. Biba, Scott I. Releasable Operating Cord Connector for Window Covering. Springs Window Fashions Division, assignee. Patent 5562140. 8 Aug. 1996. Print.
18. Tuzmen, Zeki. Safety Device for Pull Cords of Window Coverings. Newell Operating Company, assignee. Patent 5513687. 7 May 1996. Print.
19. Jacobson, Jeff A. Cordless Apparatus for Operating Blinds and Shades. Patent 5476132. 19 Dec. 1995. Print.
20. Jacobson, Jeff A. Cordless Apparatus for Operating Blinds and Shades. Patent 5787953. 4 Aug. 1998. Print.
21. Consumer Product Safety Commission. *Safety Alert: Are Your Window Coverings Safe?* Washington D.C.: Consumer Product Safety Commission, 2009. Print.
22. Cohn, H. J. Cordless Venetian Blind. Patent 2390826. 11 Dec. 1945. Print.
23. Kuhar, Otto. Cordless, Balanced Window Covering. Newell Operating Company, assignee. Patent 5531257. 2 July 1996. Print.

Annex A

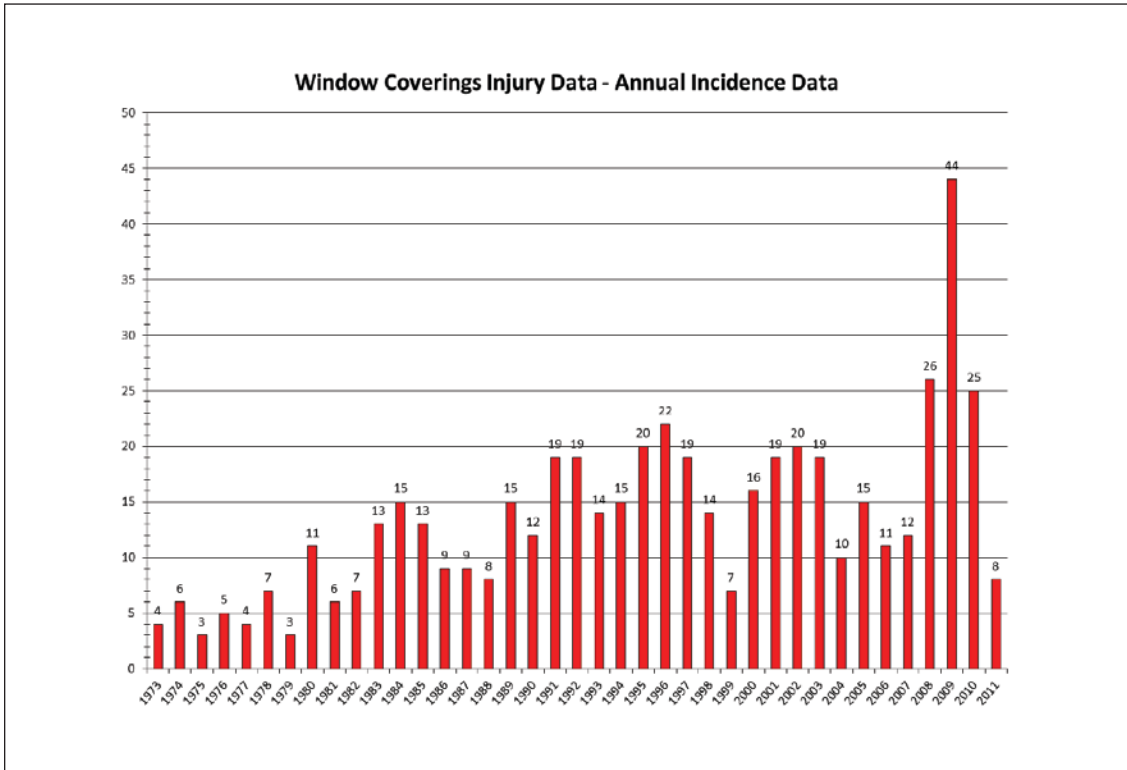

Annex B

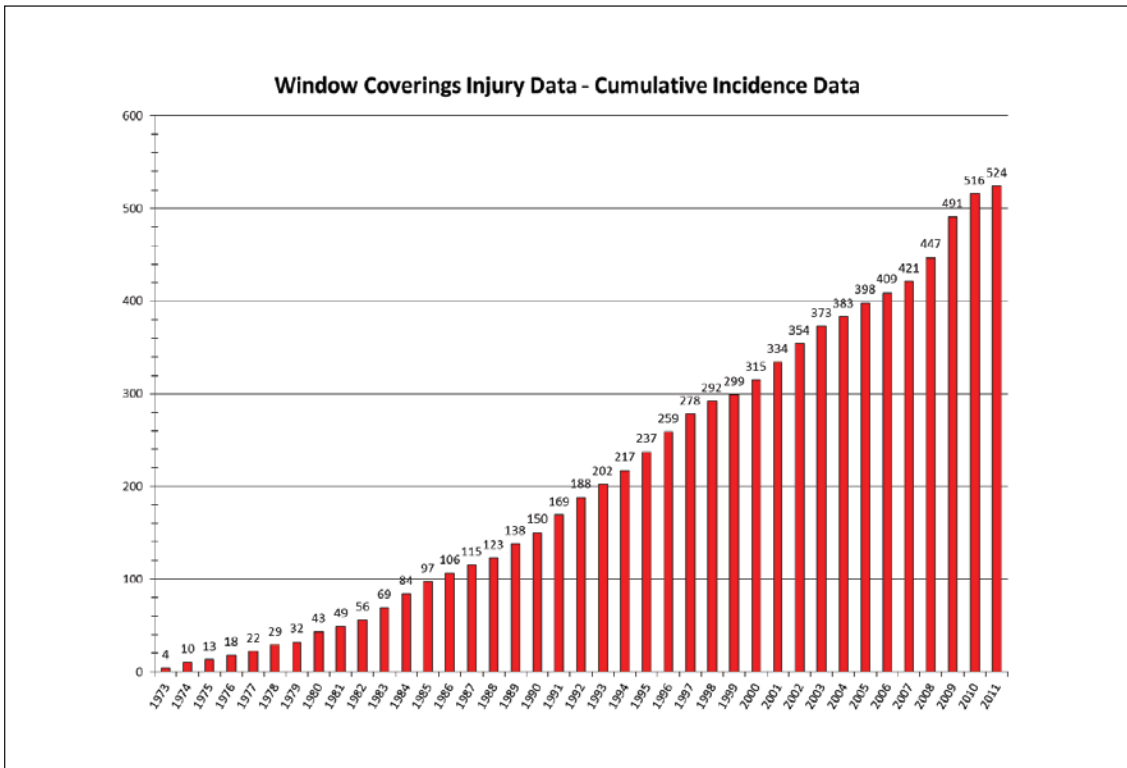

Annex C

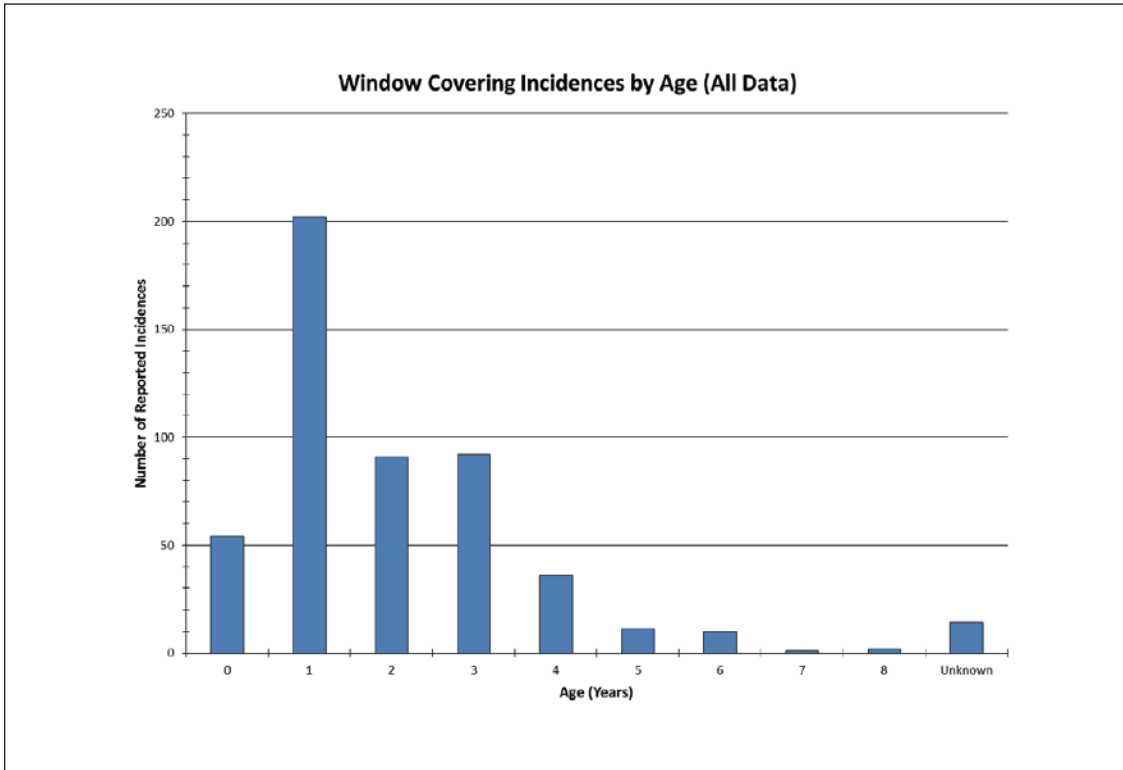

Annex D

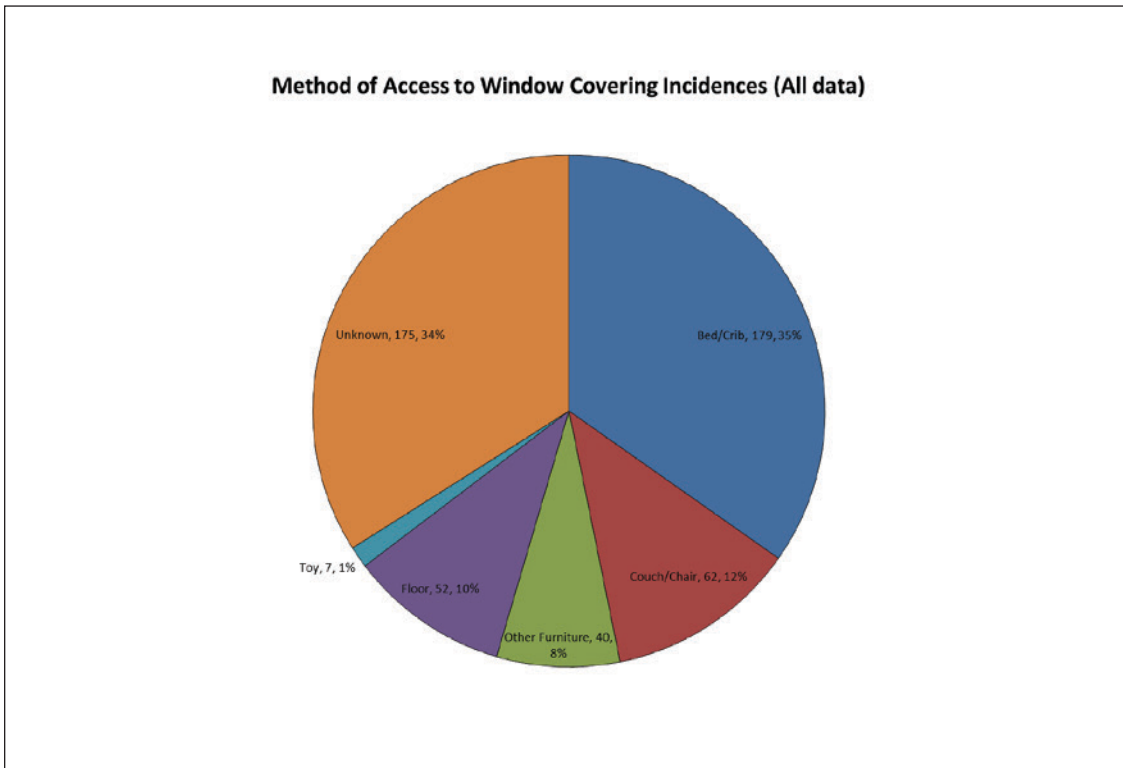

Annex E

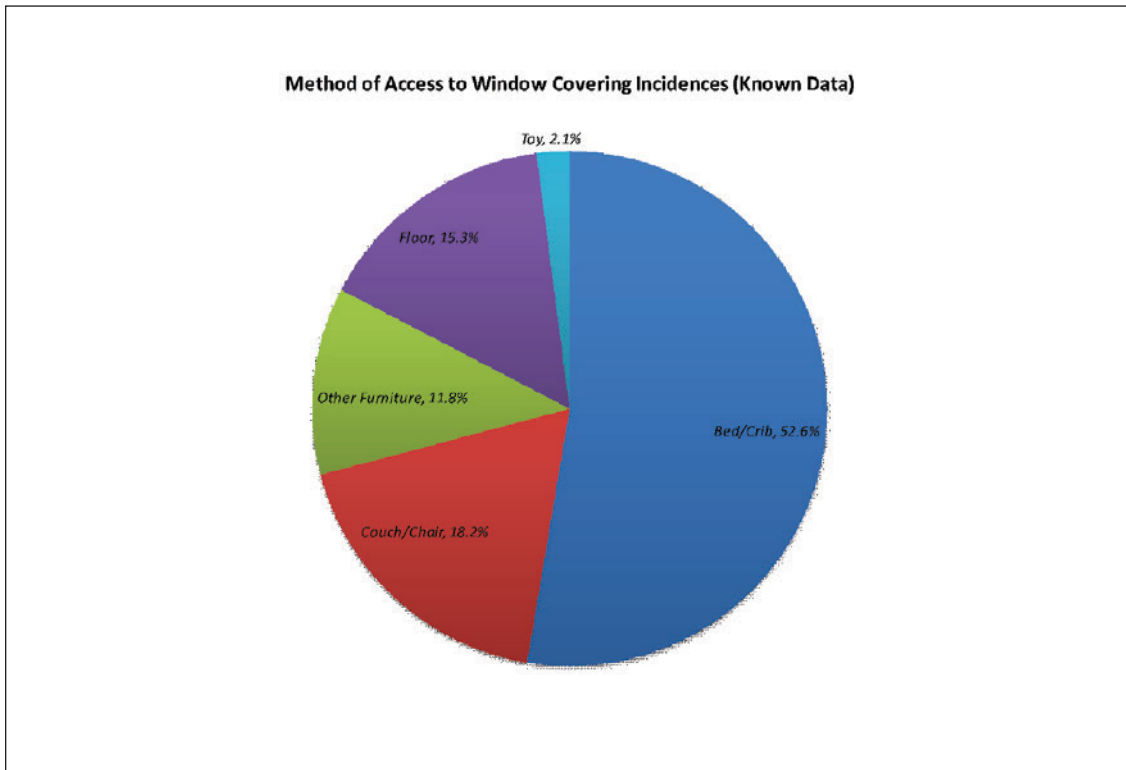

Annex F

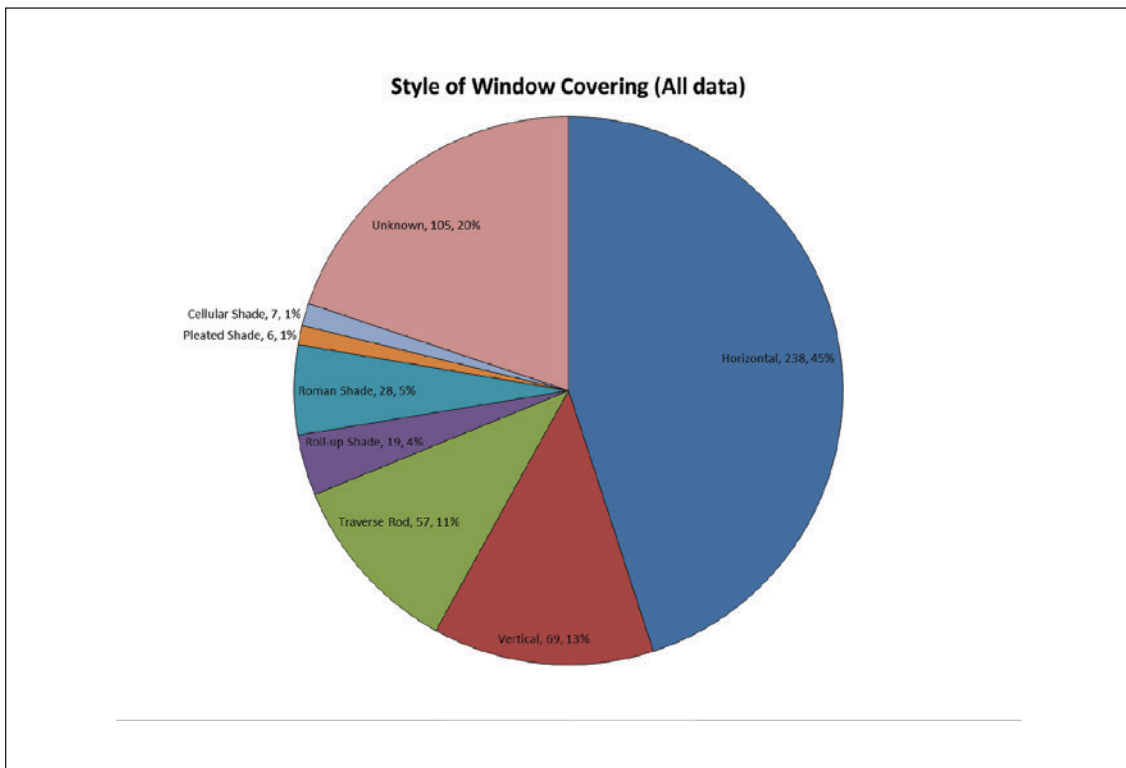

Annex G

Strangulation Type for Reported Incidences between 1973 and 2011*

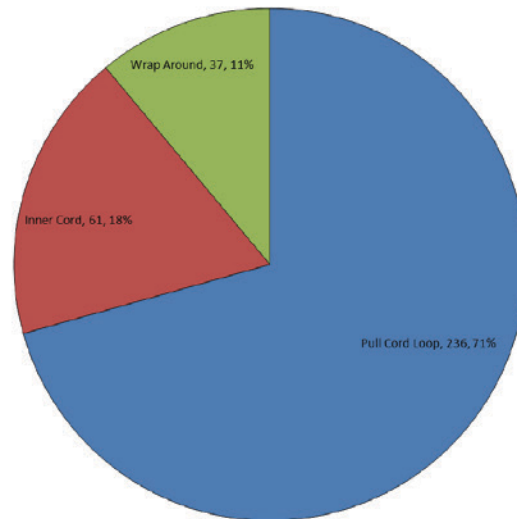

*Chart does not include unknown strangulation types